





Read this instruction carefully. See hardware and furniture part list for guidance. Be sure all parts are complete, before you assemble. Place all wooden furniture parts on a clean and flat soft surface to prevent from being scratched. Follow the figure to start assembling.

CAUTIONS : 1. Do not FULLY - TIGHTEN the nut or nut bolt until all nut or bolt is ready assembled.
 2. Do not OVER - TIGHTEN the nut or bolt to avoid causing damages to the thread.
 3. Keep all hardware parts out of reach of children.

NOTE : THE LIST AND QUANTITY SHOWN ARE FOR 1 UNIT ASSEMBLY.

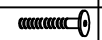
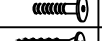
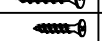
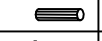
Tool needed : Screwdriver (not provider).

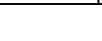
PART LIST			
ITEM	DESCRIPTION	BOX	QTY
A	HEADBOARD	1	1 PC
B	FOOTBOARD	2	1 PC
C	SIDE RAIL (L)	2	1 PC
D	SIDE RAIL (R)	2	1 PC
E	CENTER RAIL	2	1 PC
F	CENTER SUPPORT LEG	2	3 PCS
G	BED SLAT	2	1 SET
H	SIDE RAIL LEG (L)	2	1 PC
I	SIDE RAIL LEG (R)	2	1 PC
J	FOOTBOARD LEG	2	1 PC

HARDWARE LIST (BOX : 2)		
ITEM	DESCRIPTION	QTY
1	JCBC BOLT M6 x 70mm 	11 PCS
2	JCBB BOLT M8 x 30mm 	4 PCS
3	WOOD SCREW M4 x 32mm 	9 PCS
4	WOOD SCREW M4 x 20mm 	2 PCS
5	WOOD DOWEL M8 x 30mm 	10 PCS
6	M4 ALLEN KEY (BALL SHAPE) 	1 PC
7	M5 ALLEN KEY (BALL SHAPE) 	1 PC

STEP 1

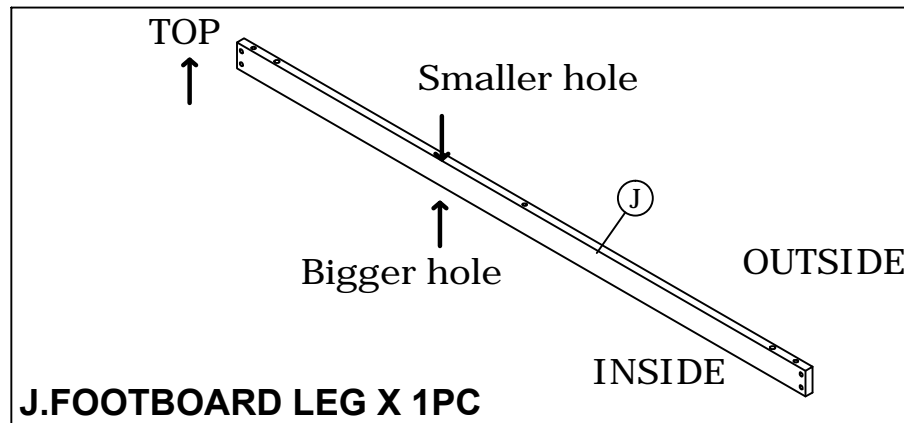
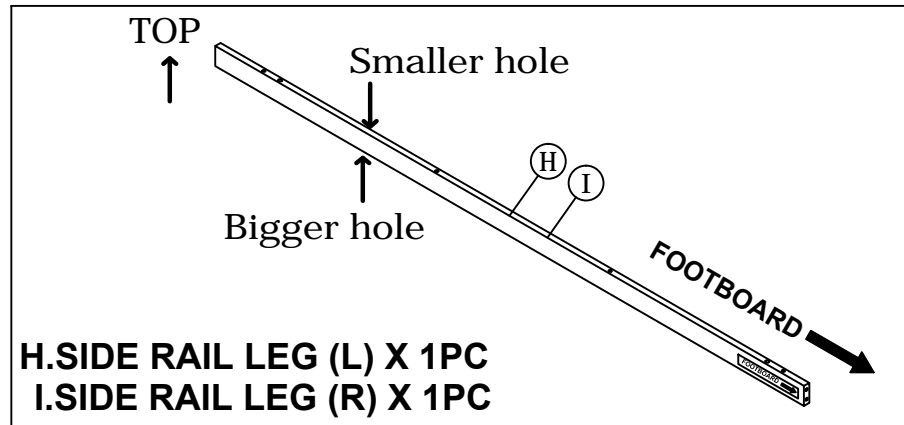

STEP 2

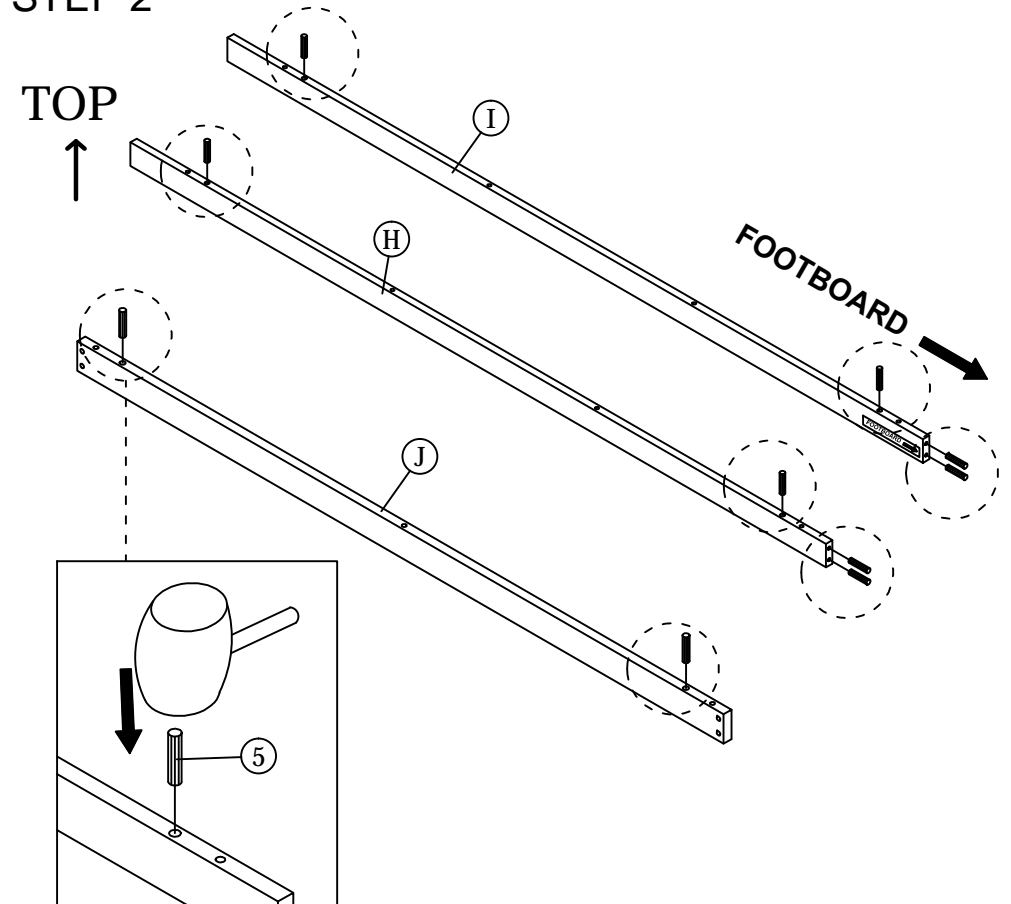

ASSEMBLY INSTRUCTIONS

STEP 3

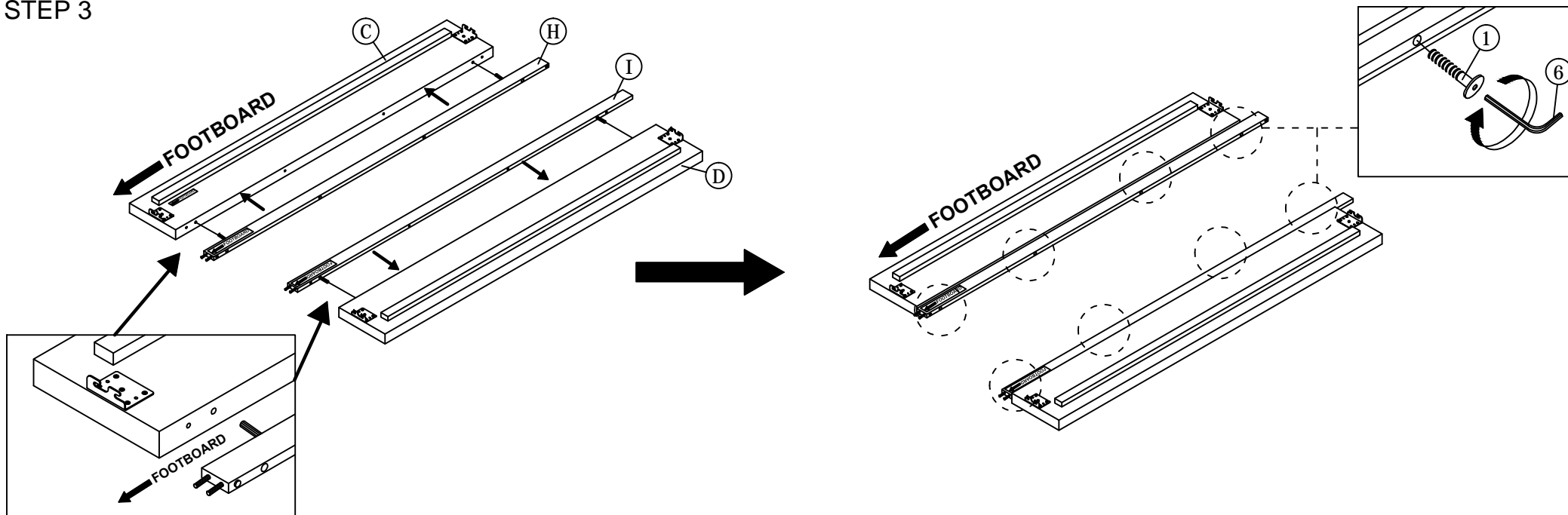

STEP 4

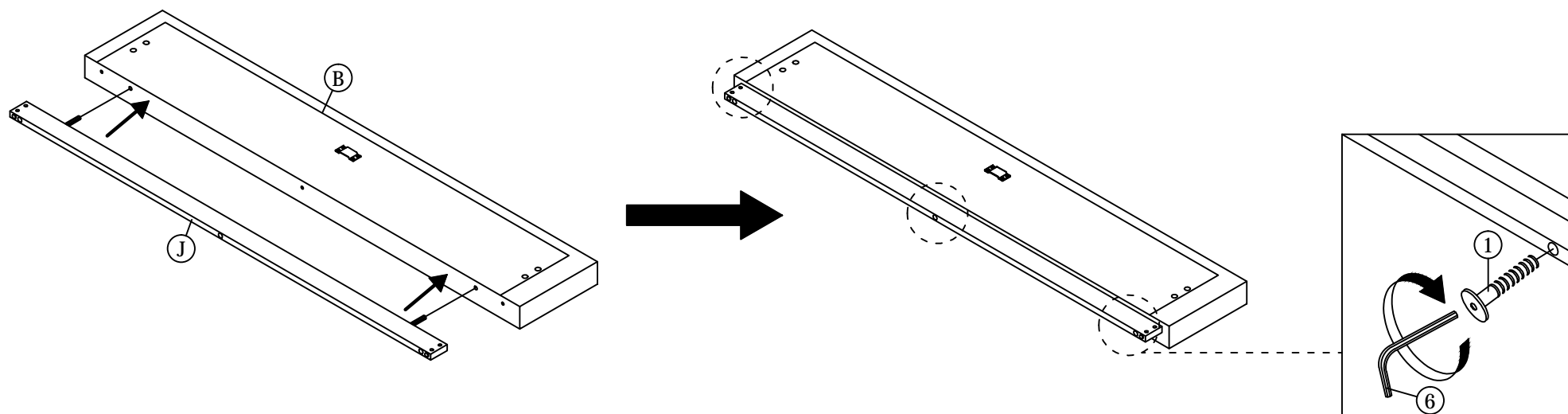

ASSEMBLY INSTRUCTIONS

STEP 5

STEP 5.1

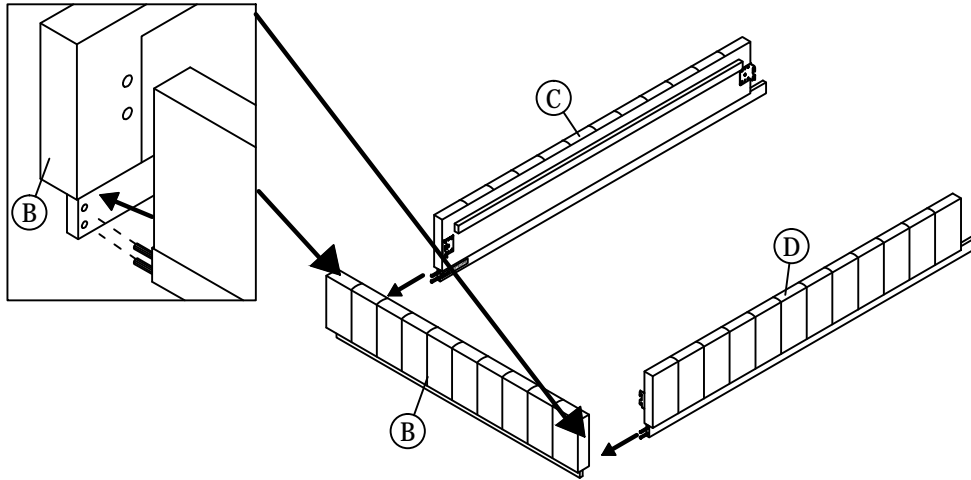

STEP 5.2

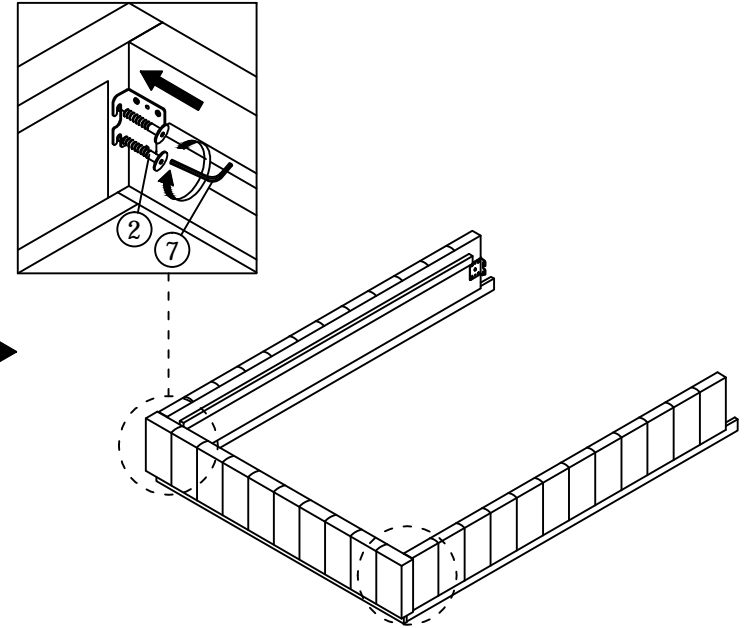

STEP 6

STEP 6.1

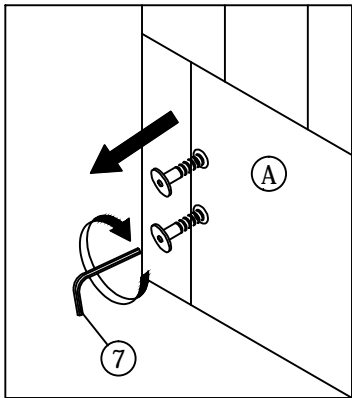

STEP 6.2

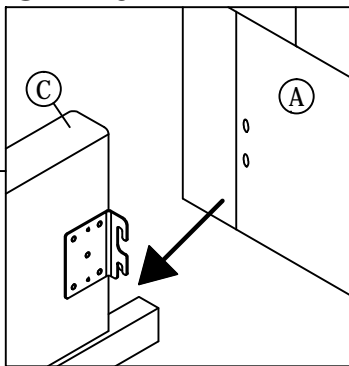

STEP 6.3

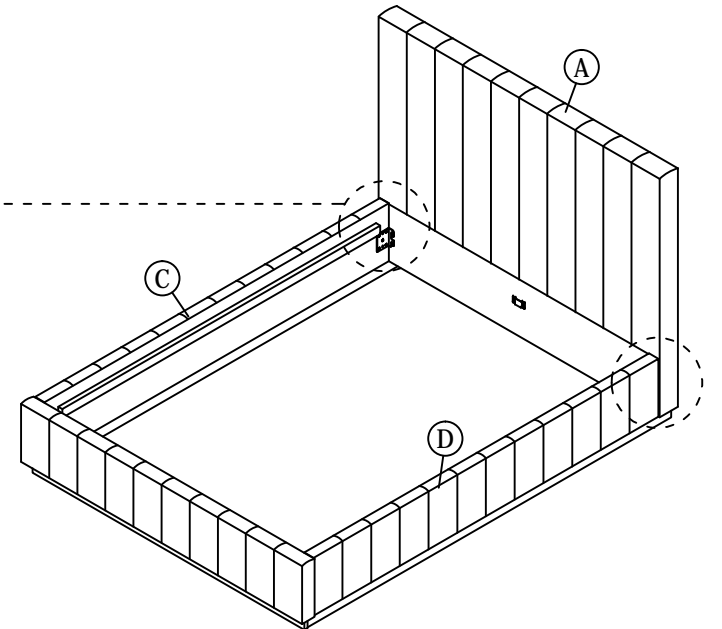
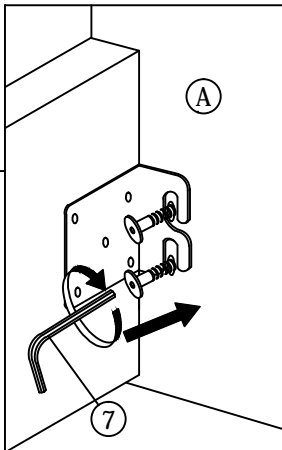

ASSEMBLY INSTRUCTIONS

STEP 7

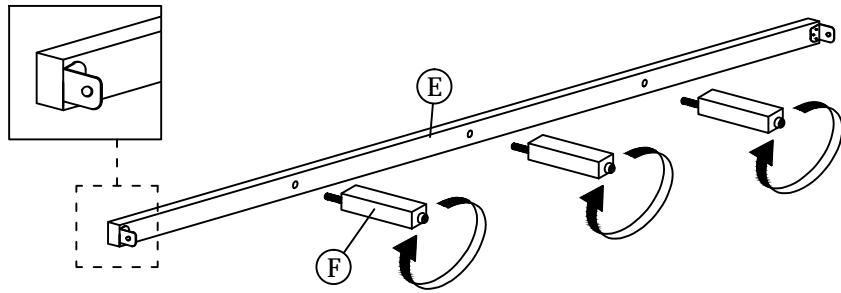

STEP 8

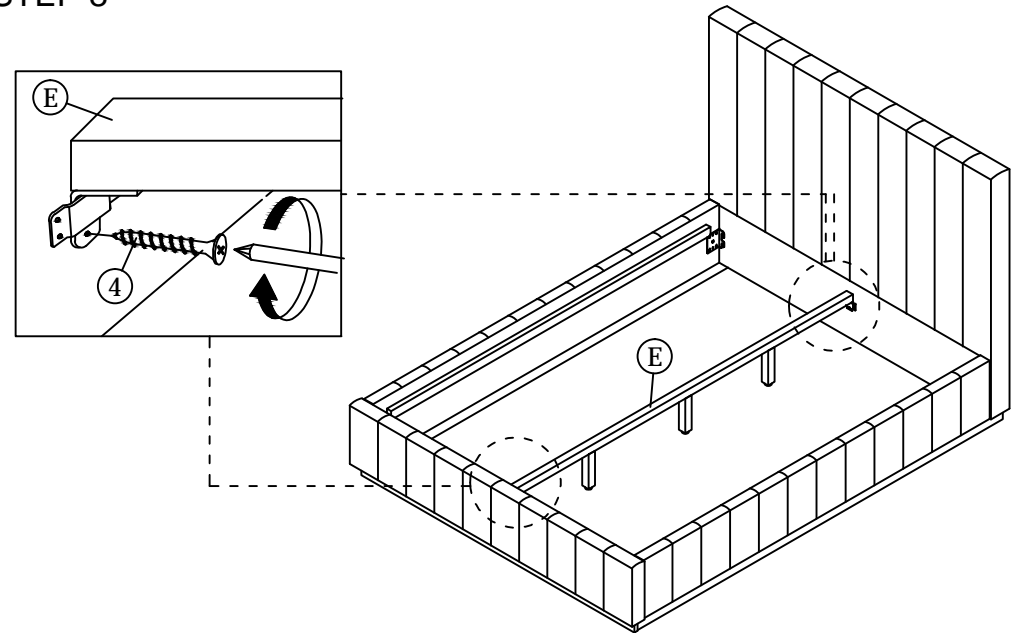

STEP 9

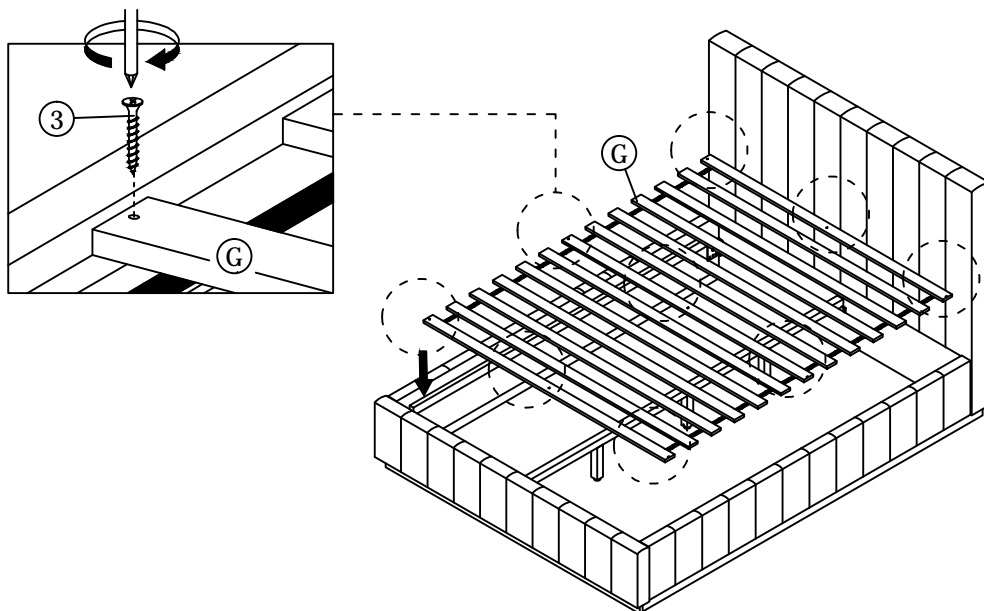

STEP 10

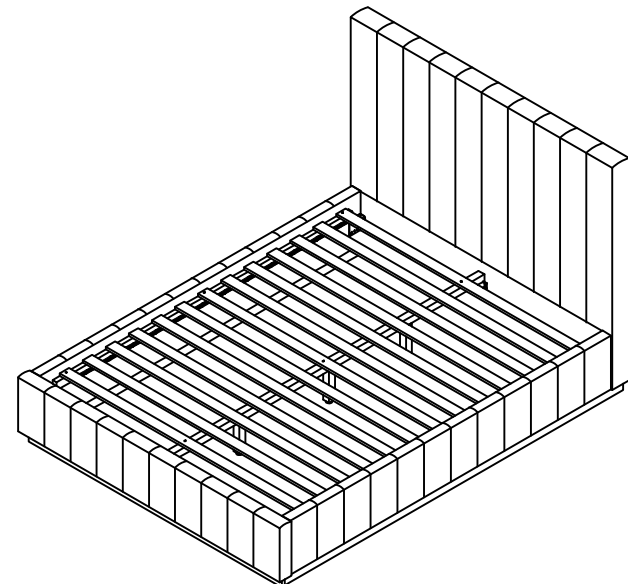

*** When moving the bed position, the center support legs must be adjust to be straight to avoid any broken problem.**