

0218 Queen Bed

Assembly Instructions

WI-0423

1 Assembled View

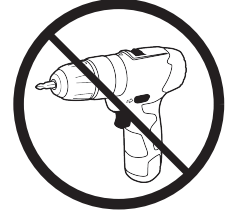
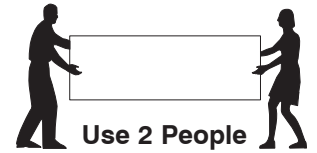
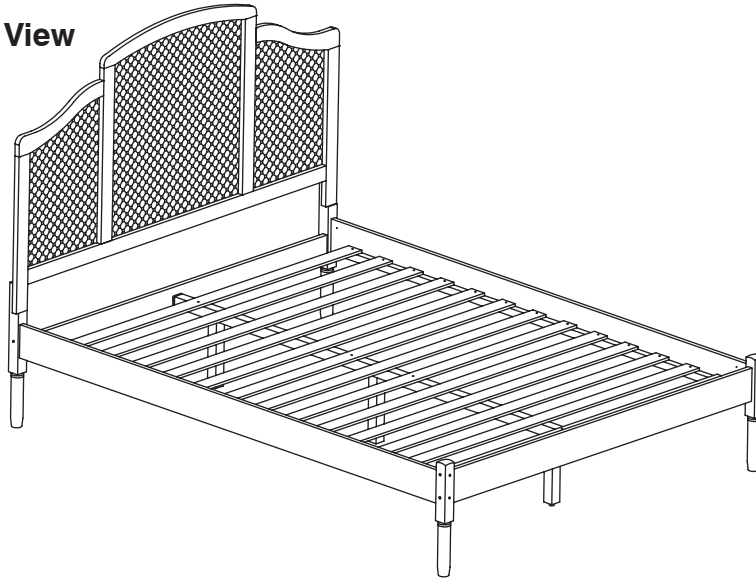

Note: Do not assemble using power tools. This can cause the bolts to be overtightened.

2 Parts List

Parts in Box A:

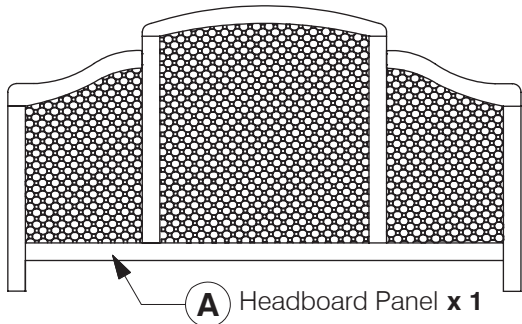

B Headboard Support x 1

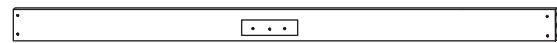

C Footboard Panel x 1

Parts in Box B:

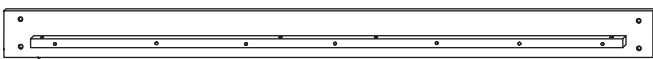

D Side Rail x 2

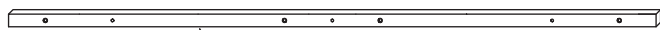

E Long Support x 1



F Support Leg x 3

G Headboard Post (Right) x 1

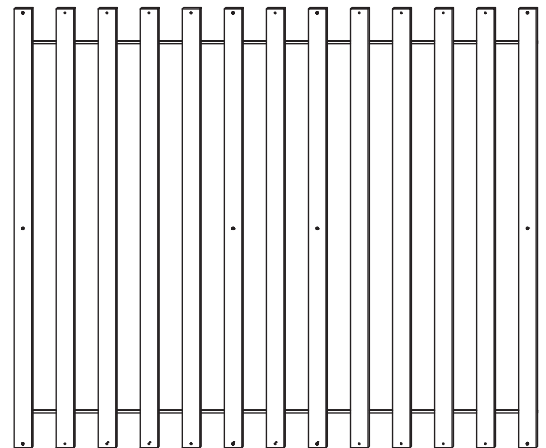
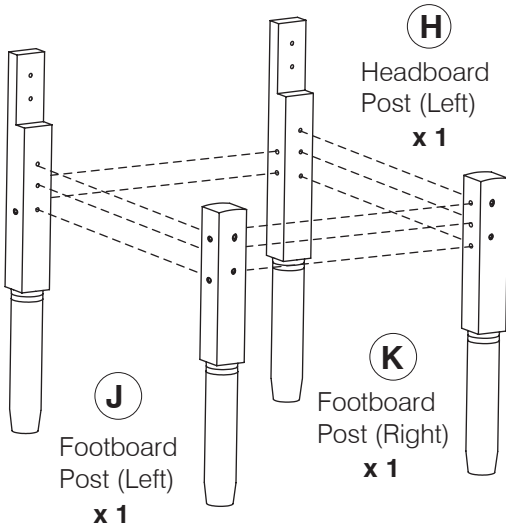

L Set of Bed Slats x 1

0218 Queen Bed

Assembly Instructions

WI-0423

3 Hardware List

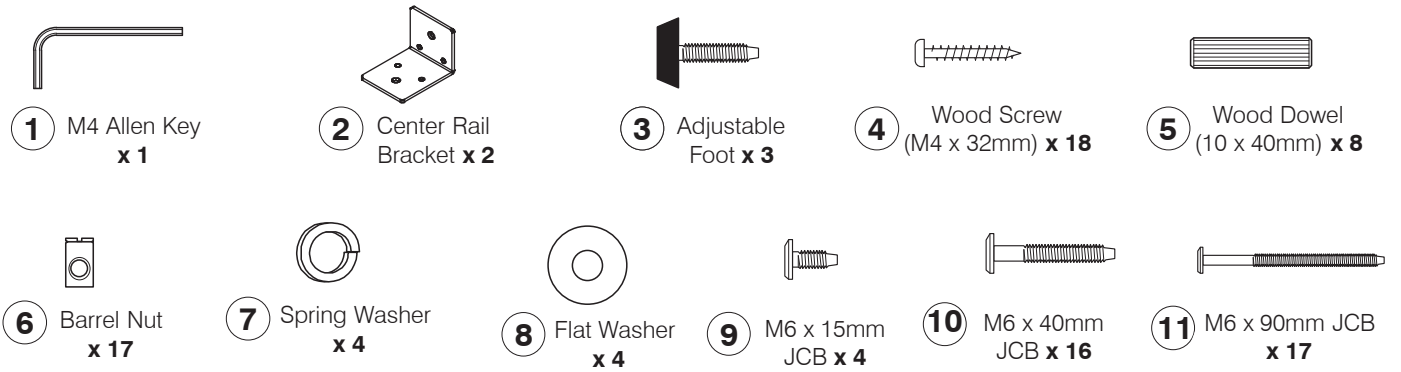

4 Assembled the Support Leg (F) to the Long Support (E).

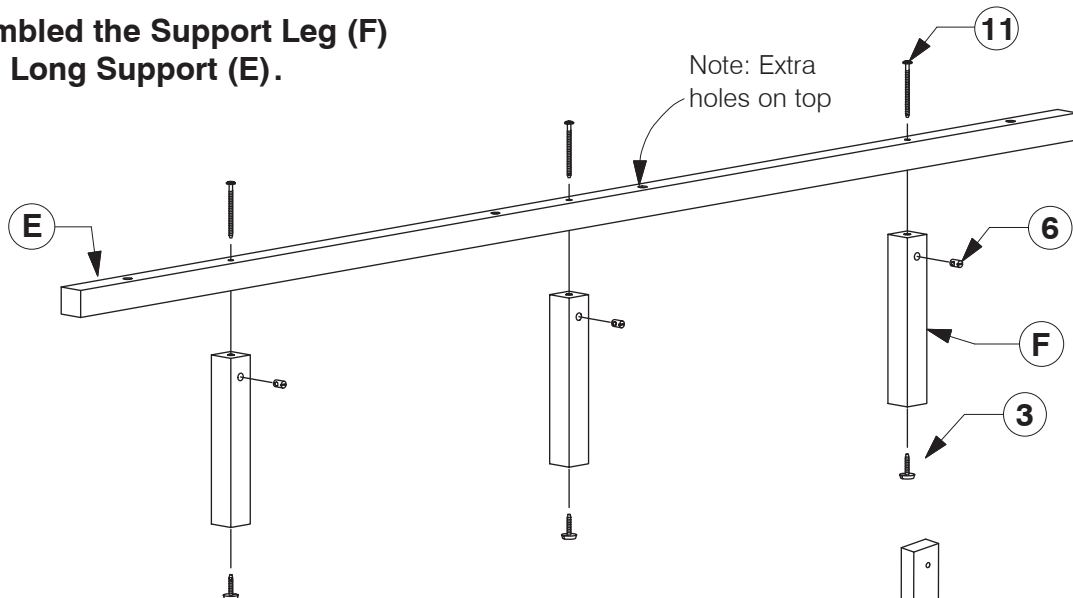

5 Fit the Center Rail Bracket (2) to the Headboard Support (B). Assemble the Headboard Post (G & H) to the Headboard Support (B).

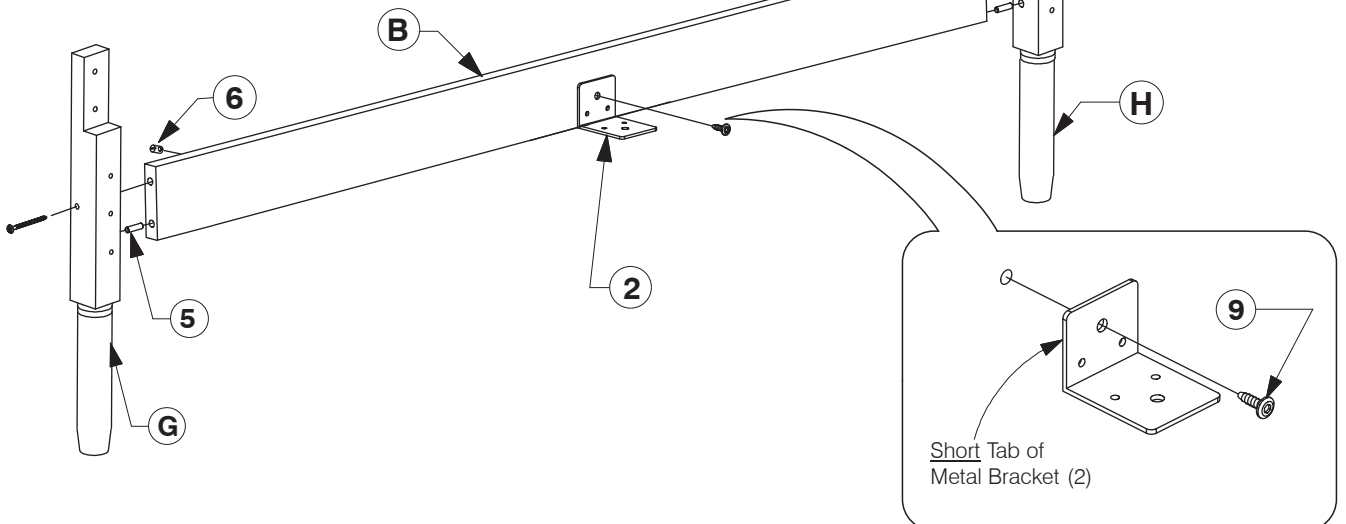

0218 Queen Bed

Assembly Instructions

WI-0423

- 6** Fit the Center Rail Bracket (2) to the Footboard Panel (C).
Assembled the Footboard Post (J & K) to the
Footboard Panel (C).

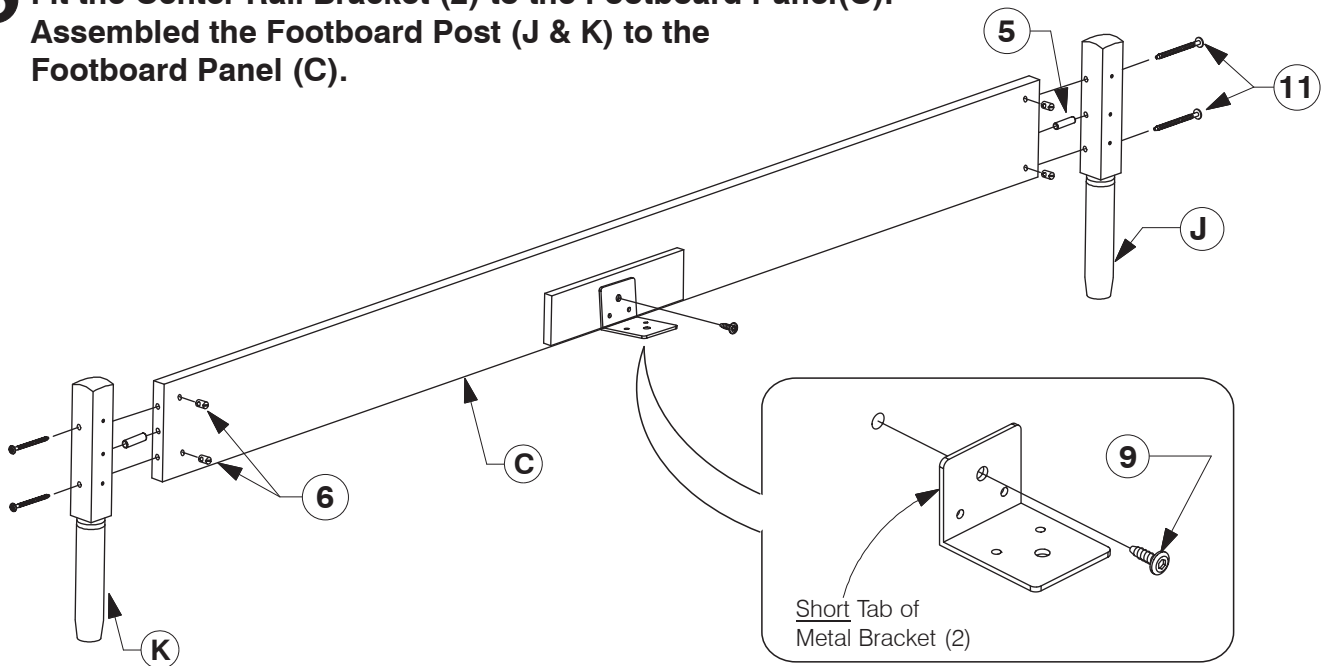

- 7** Fit the Headboard Panel (A) to the
Headboard Post (G & H).

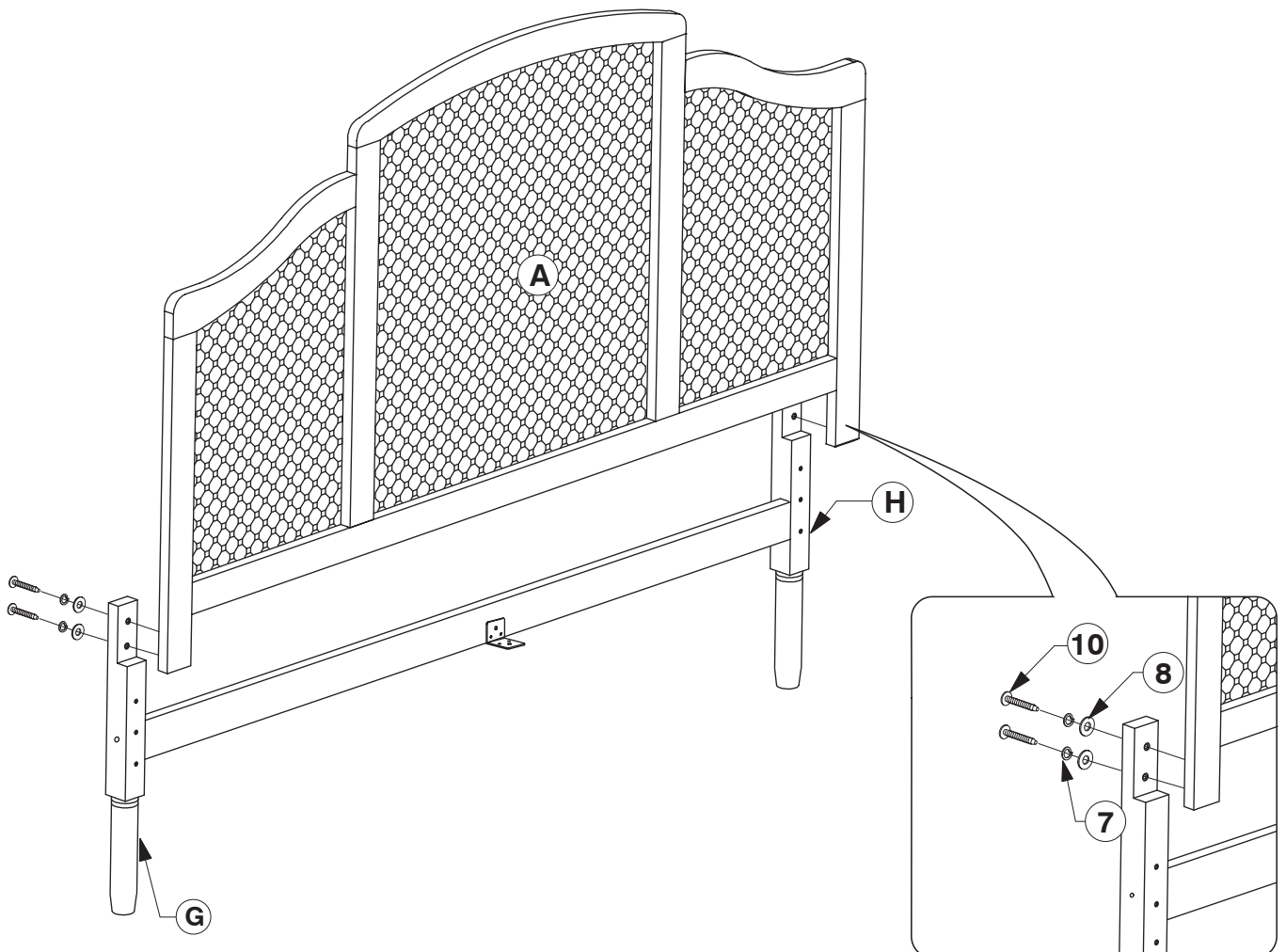

0218 Queen Bed

Assembly Instructions

WI-0423

- 8** Assemble the Side Rail (D) to the Headboard Post (G & H) and Footboard Post (J & K).

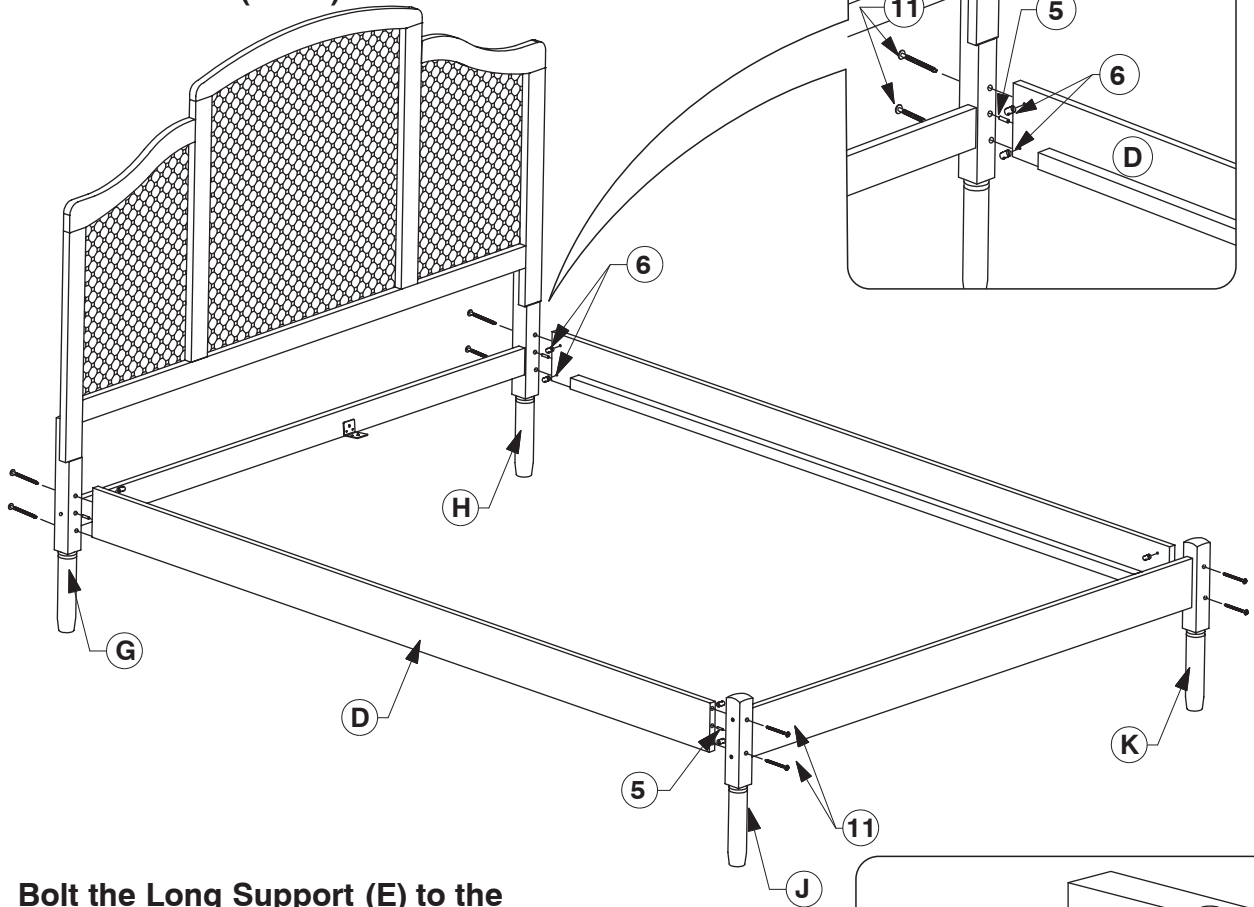

- 9** Bolt the Long Support (E) to the Center Rail Brackets (2) on the Headboard Support (B) & Footboard Panel (C).

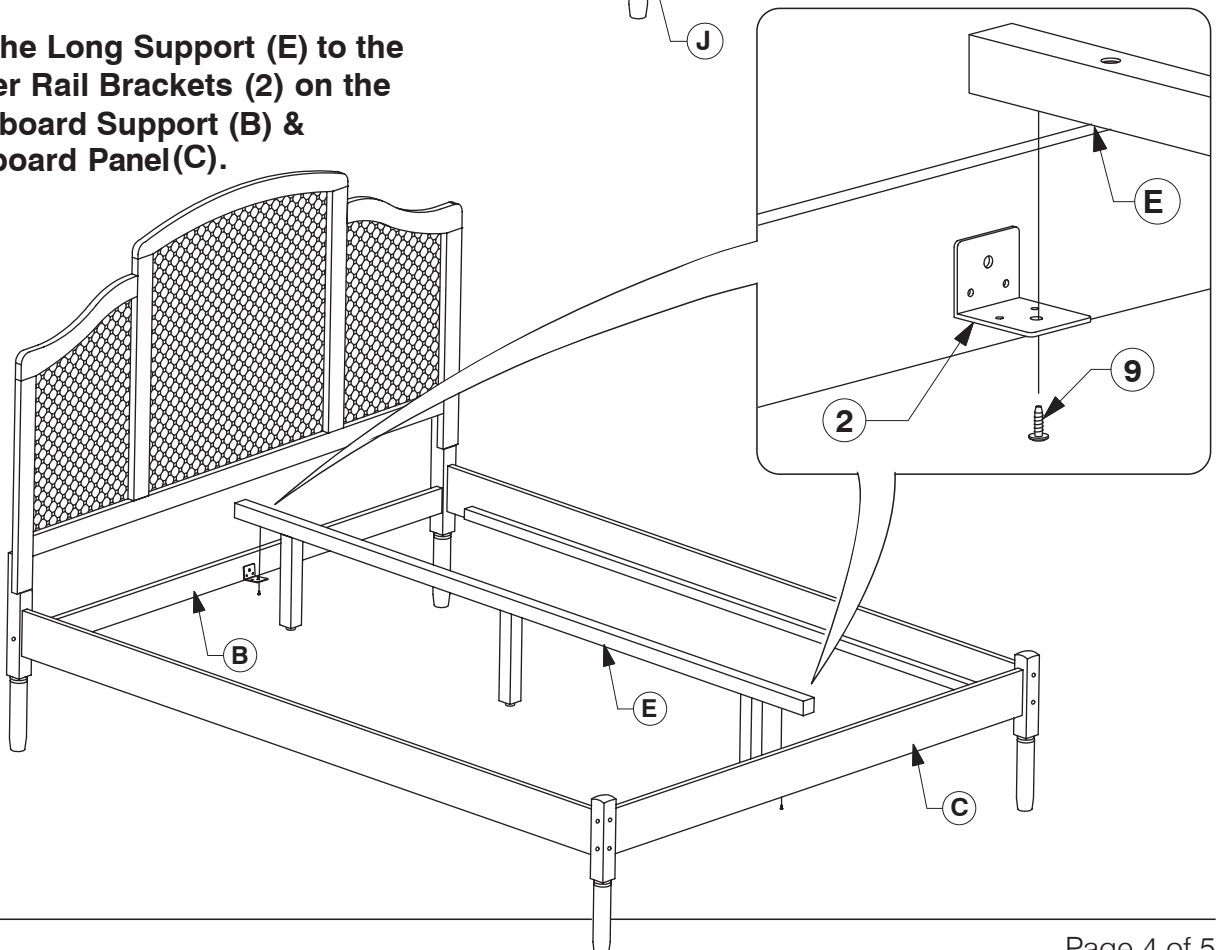

0218 Queen Bed

Assembly Instructions

WI-0423

10 Screw the Bed Slats (L) to the Side Rail (D).

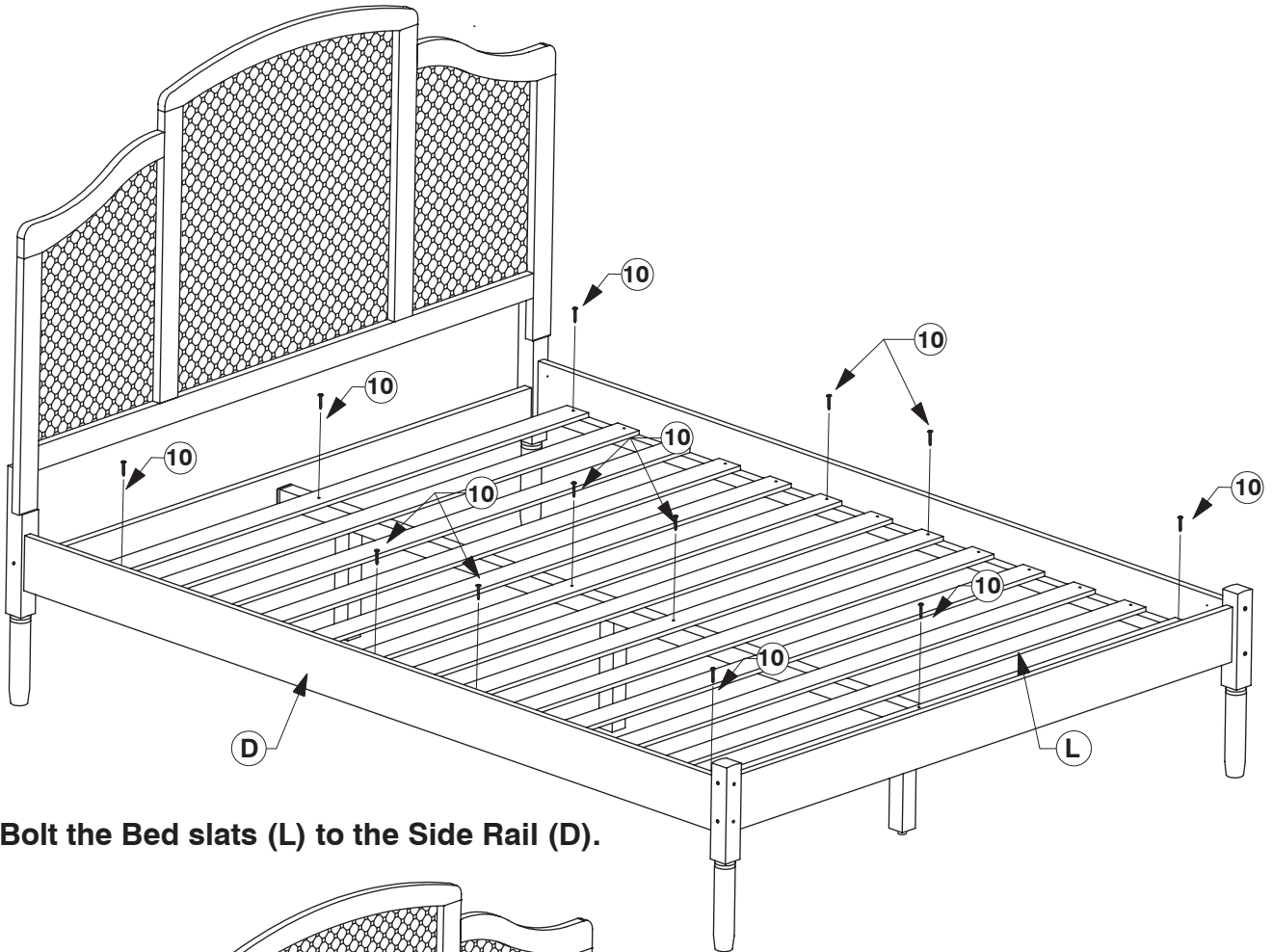

10 Bolt the Bed slats (L) to the Side Rail (D).

