

# MODEL : SE SC 294WI-WG

PANEL POSITION

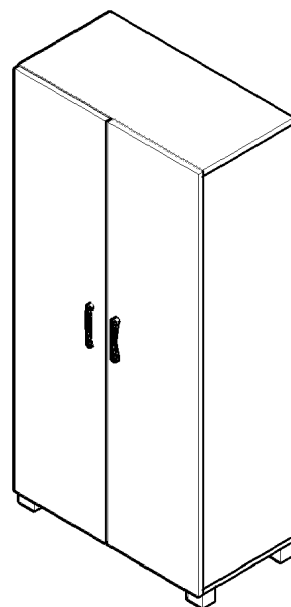

	HARDWARE	QUANTITY
A	SCREW M6x50MM	12 PCS
B	IRON SHELF SUPPORT	16 PCS
C	PVC HANDLE 128MM SCREW M4x28MM	2 PCS 4 PCS
D	HINGES 5/8" SCREW M3.5x16MM	6 PCS 36 PCS
E	PVC CABINET LEG SCREW M4x28MM	4 PCS 8 PCS
F	PVC "H" RAIL	1 PC
G	POWER PIN	30 PCS
H	ALLEN KEY	1 PC
I	NYLON COTTON	1 PC
J	WALL PLUG	1 PC
K	SCREW M4x28MM	1 PC
L	WOSE	2 PCS
M	SCREW M3.5x16MM	1 PC
N	BUFFER	4 PCS

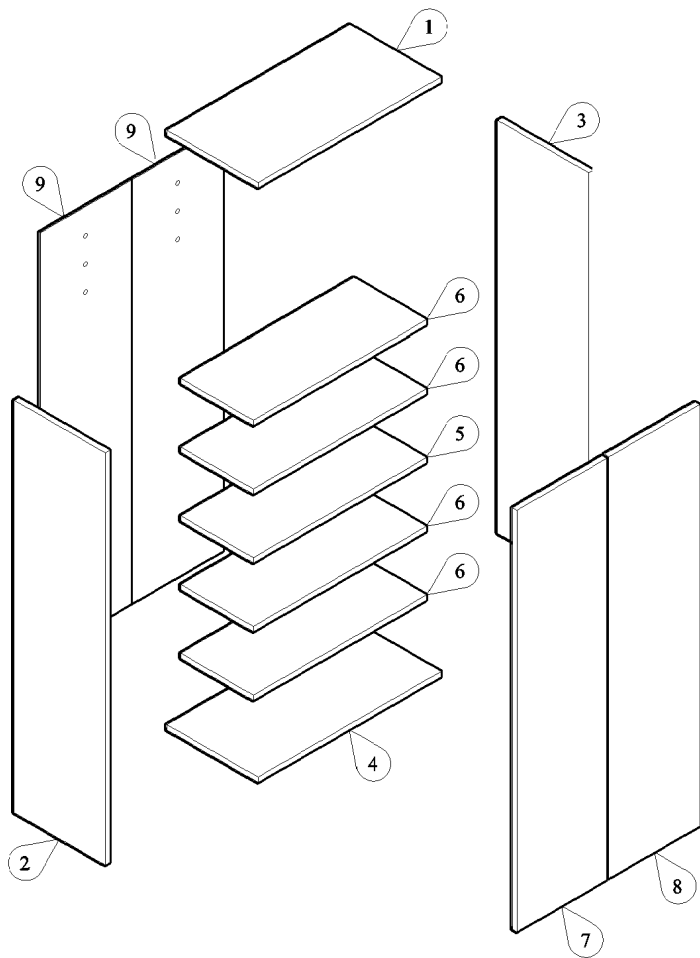

CHEMICAL

HANDLE WITH CARE

KEEP DRY

HARD SURFACE

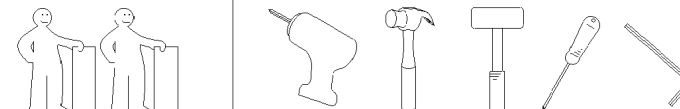

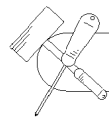

# START ASSEMBLY

## STEP 1

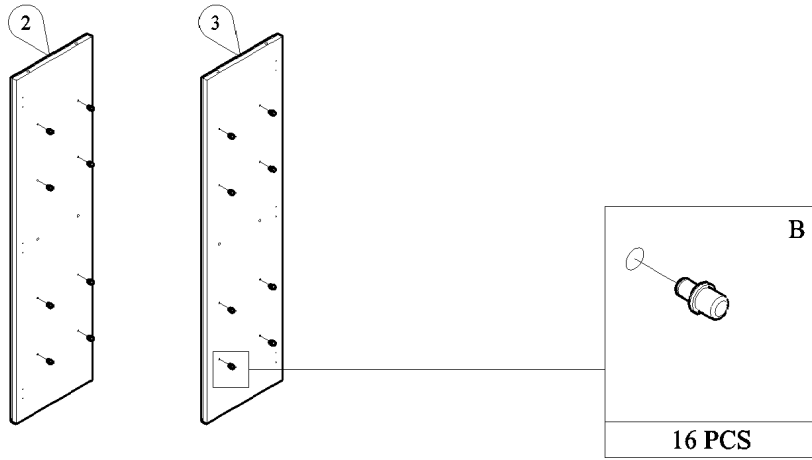

## STEP 2

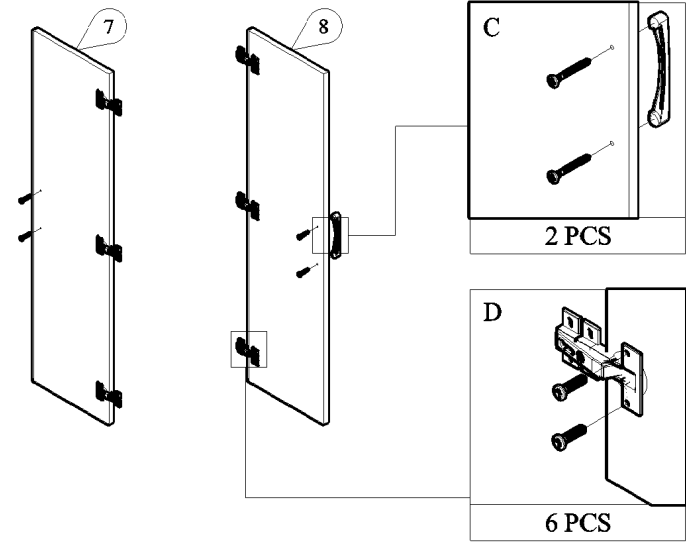

## STEP 3

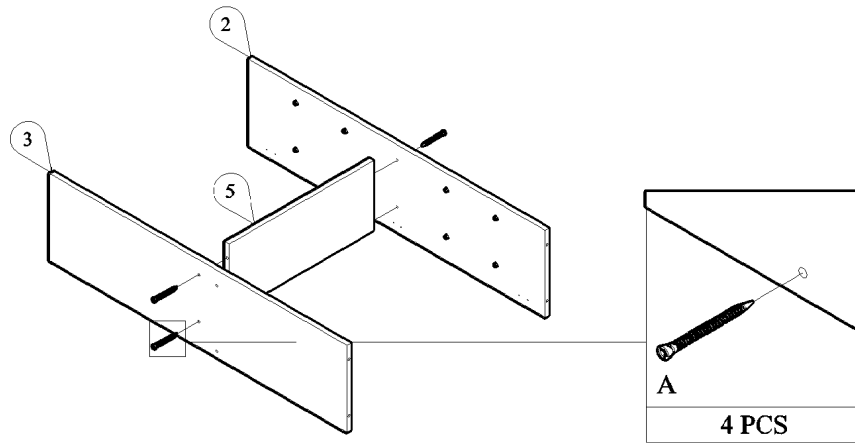

## STEP 4

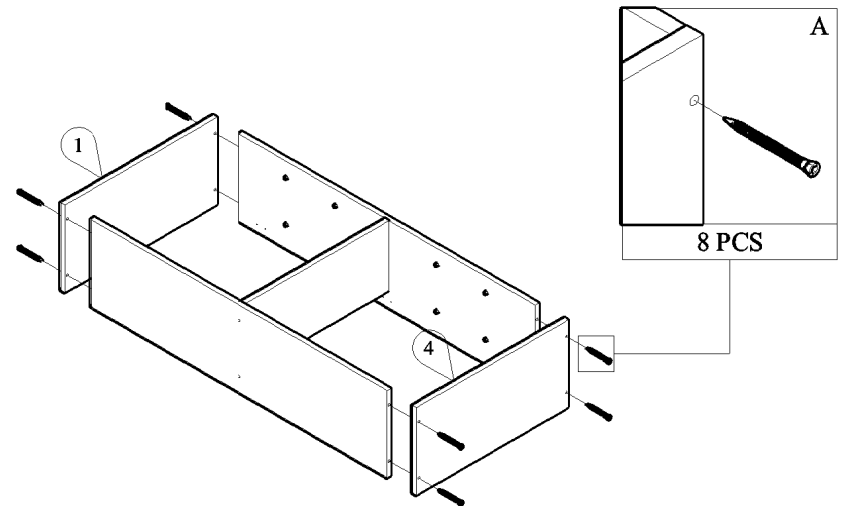

STEP 5

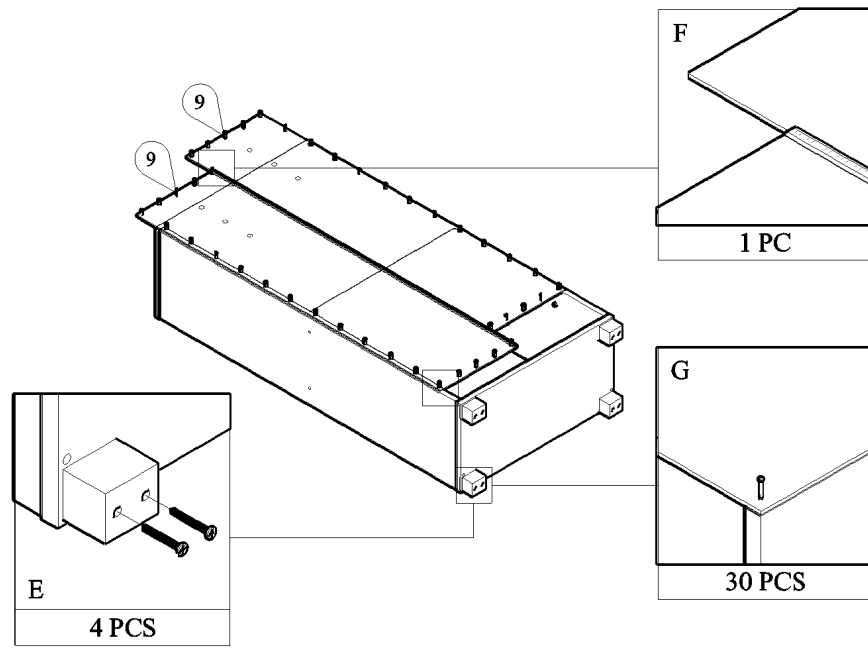

STEP 6

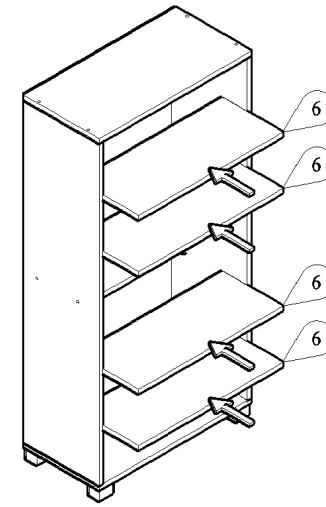

STEP 7

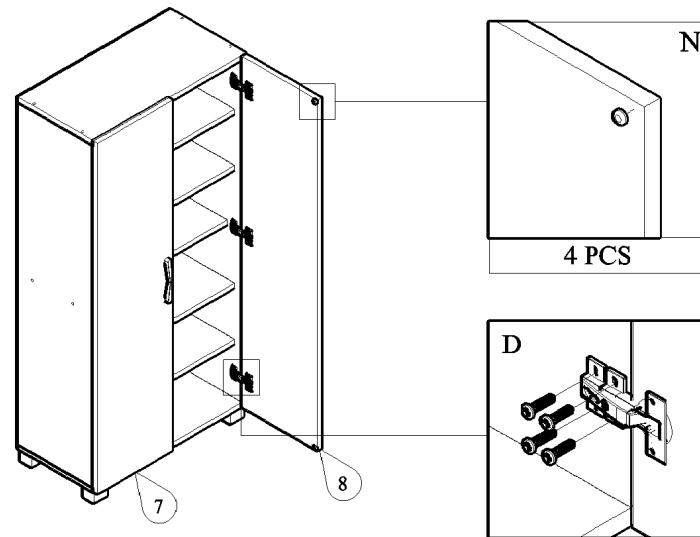

STEP 8

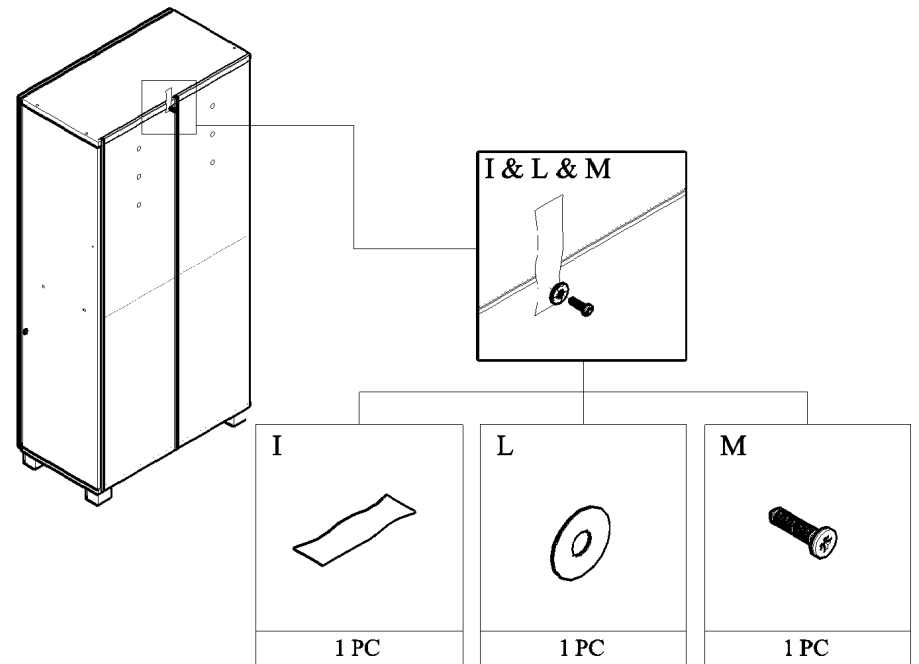

STEP 9

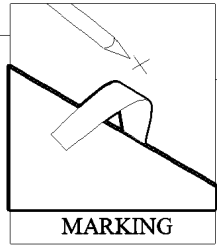
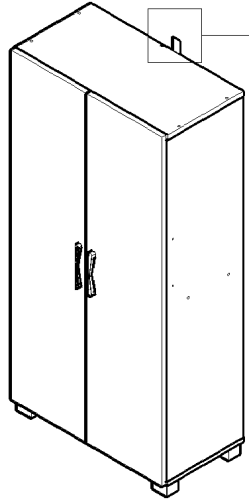

MARKING

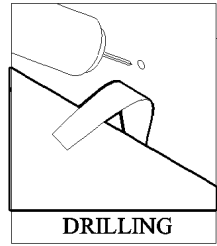

DRILLING

STEP 10

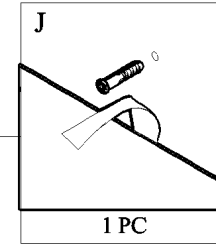
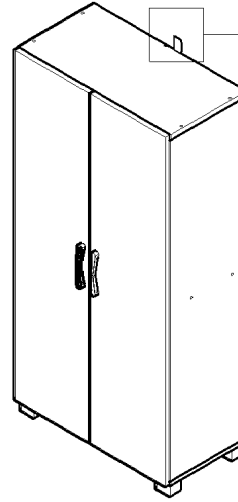

1 PC

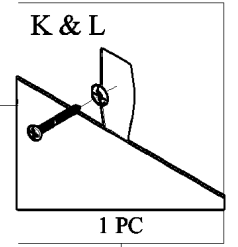

1 PC

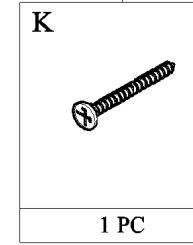

1 PC

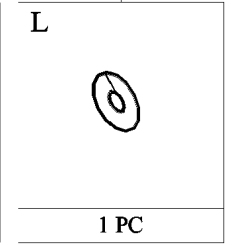

1 PC

COMPLETED

