



ASSEMBLY INSTRUCTIONS

MODEL : VERA SOFA

IMPORTANT NOTE :

- * PLACE ALL WOODEN PARTS ON A CLEAN AND SMOOTH SURFACE SUCH AS A RUG OR CARPET TO AVOID THE PARTS FROM BEING SCRATCHED.
- * PLEASE FOLLOW ASSEMBLY INSTRUCTIONS STEP BY STEP.
- * DO NOT FULLY TIGHTEN ALL SCREWS UNTIL THE CHAIR PARTS HAVE BEEN ASSEMBLED.

| HARDWARE LIST | | | PART LIST | | |
|---------------|--|------|-----------|-------------------|-----|
| A | JCBC M6 x 60mm + S/W M6 + F/W M6 x 13mm  | 4PCS | 1 | LEG (RIGHT) | 1PC |
| | | | 2 | LEG (LEFT) | 1PC |
| B | JCBC M6 x 50mm + S/W M6 + F/W M6 x 13mm  | 4PCS | 3 | STRETCHER (FRONT) | 1PC |
| | | | 4 | STRETCHER (BACK) | 1PC |
| C | ALLEN KEY M4  | 1PC | 5 | CUSHION SEAT | 1PC |

PLEASE NOTE :

(1) DO NOT FULLY-TIGHTEN THE NUTS AND BOLTS UNTIL ALL PARTS HAVE BEEN ASSEMBLED.

(TO AVOID CAUSING DAMAGE TO THE THREADS, DO NOT OVER-TIGHTEN THE NUTS AND BOLTS.)

(2) KEEP ALL PARTS OUT OF THE REACH OF CHILDREN.

STEP 1

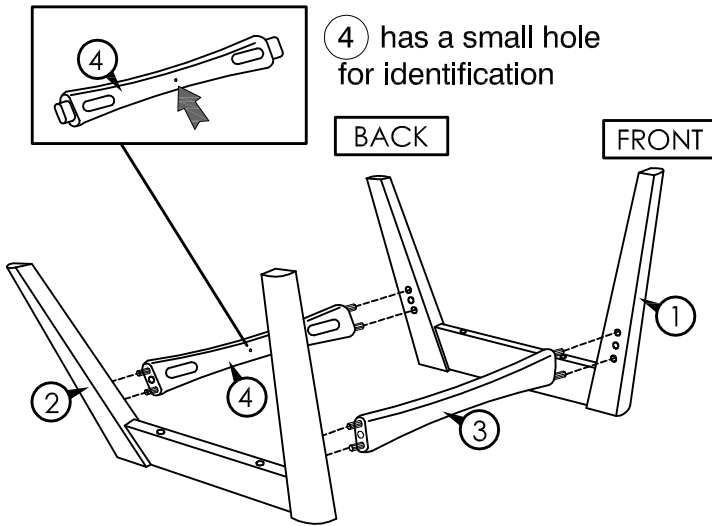

STEP 2

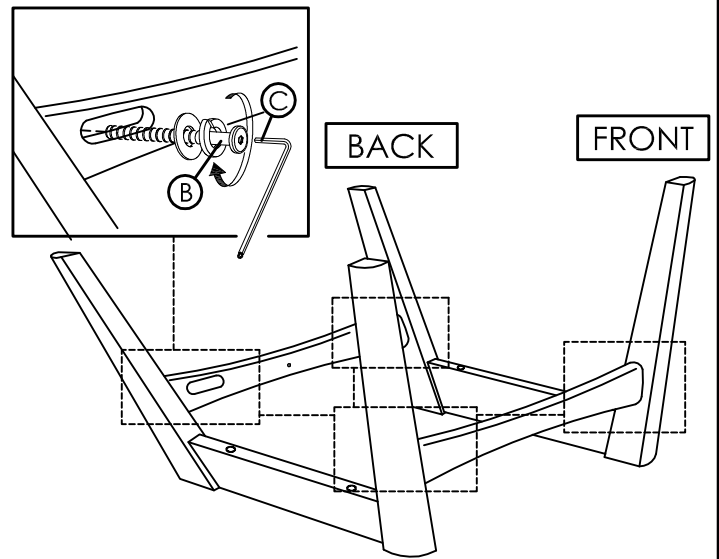

STEP 3

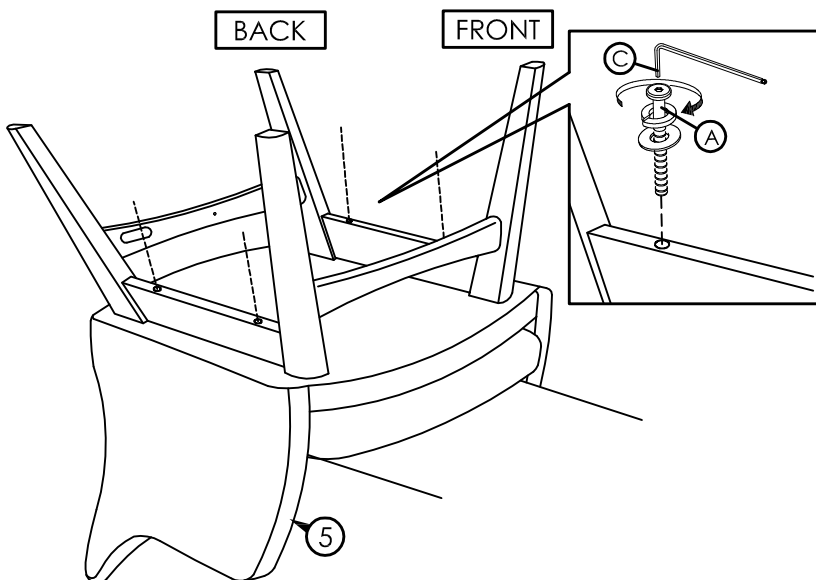

STEP 4

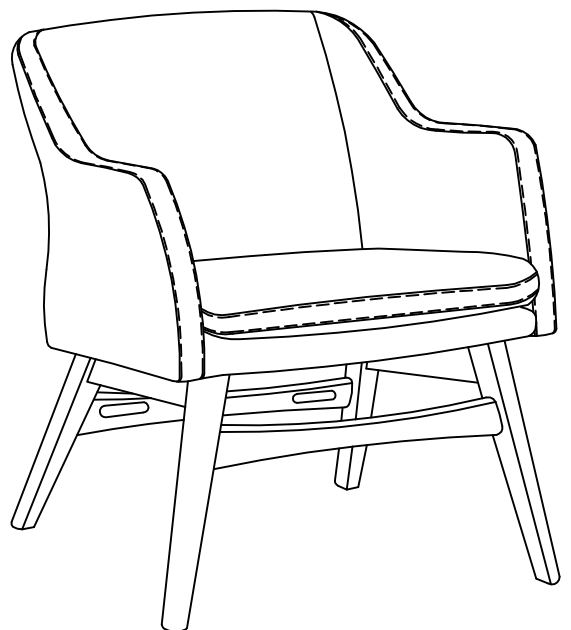

COMPLETED CHAIR ASSEMBLY.