

ASSEMBLY INSTRUCTION
MODEL : ST 2 / SIDE TABLE

Before you begin, please follow assembly instruction carefully.
 Then follow them step by step.

STEP 1

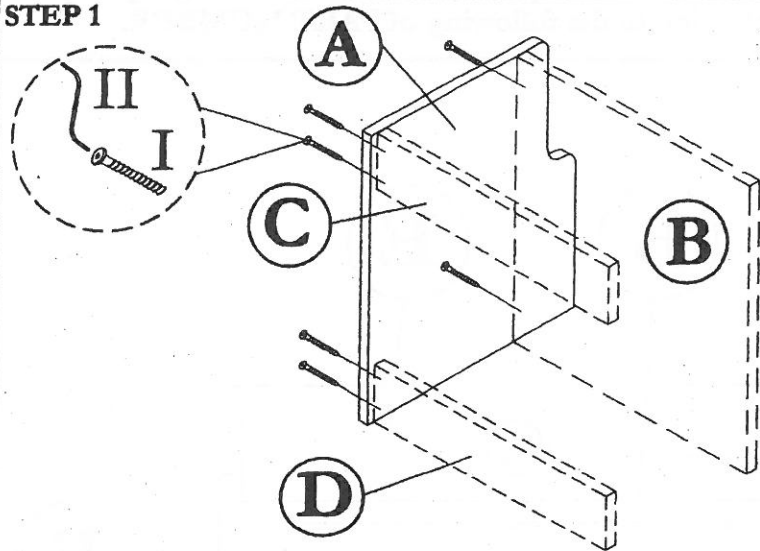

STEP 2

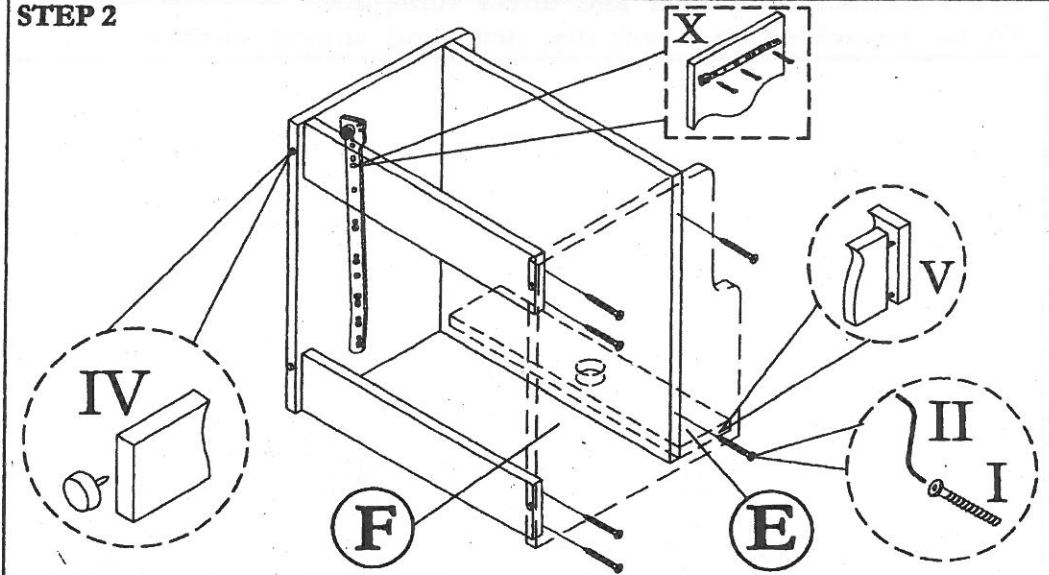

STEP 3

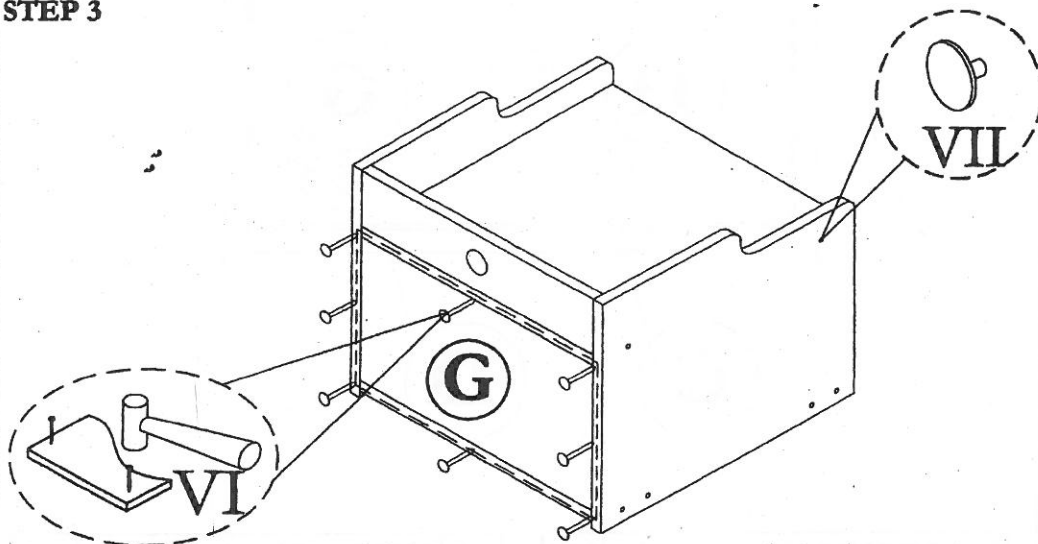

STEP 4

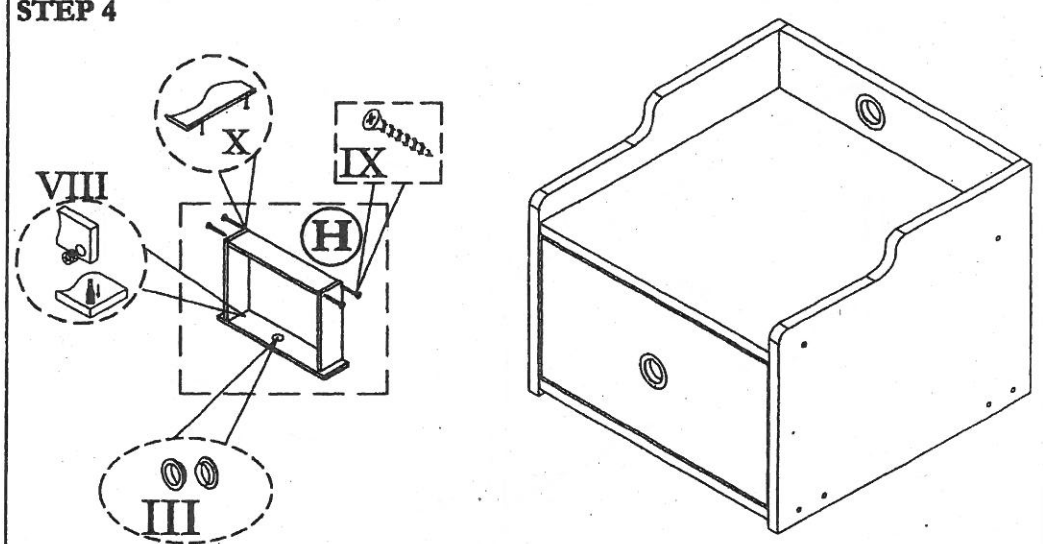

HARDWARE LIST

NO	DESCRIPTION	QTY
I	JCBCW SCREW M6 x 45	12pcs
II	M4 ALLEN KEY	1pc
III	HANDLE	2sets

IV	PVC NAIL WITH PIN	4pcs
V	M8 x 30 PLASTIC DOWEL	4pcs
VI	NAIL	15pcs
VII	CAP SMALL	12pcs
VIII	Q-FIT	4sets

IX	M8 X 32 CHIPBOARD SCREW	4pcs
X	DRAWER SLIDER & SCREW M3.5 x 12	1sets

CAUTION:

To clean use soft, dry cloth. Do not use detergent or chemicals
Avoid contact with water and direct sunlight.
To be assembled on a soft, dry, clean and smooth surface.

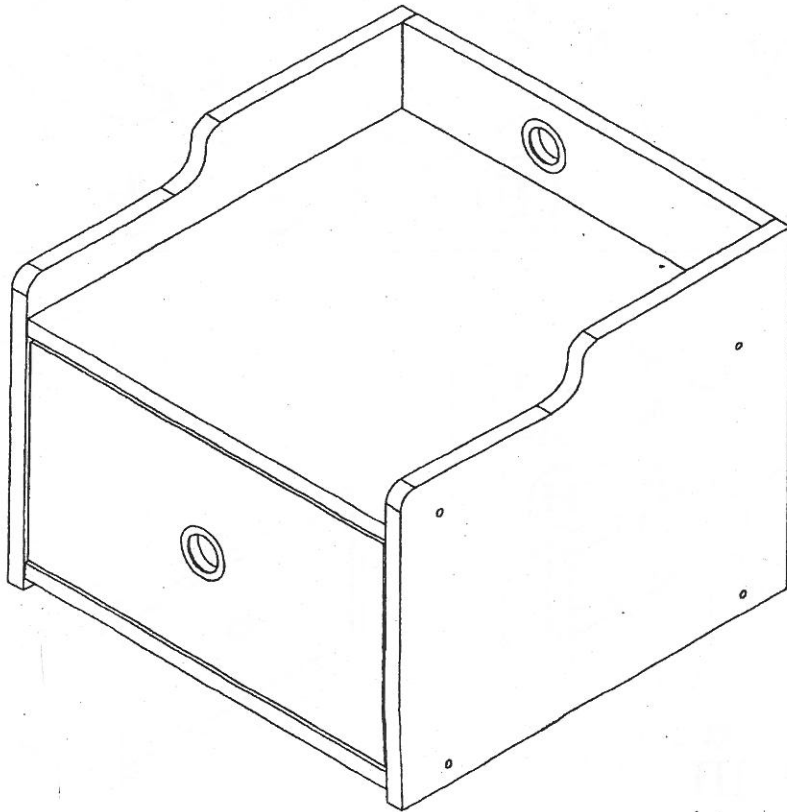

COMPLETE SET

ORDERING REPAIR PARTS

In order to obtain smooth and rapid service when ordering repair parts, please give full attention to the following of PART NUMBER.

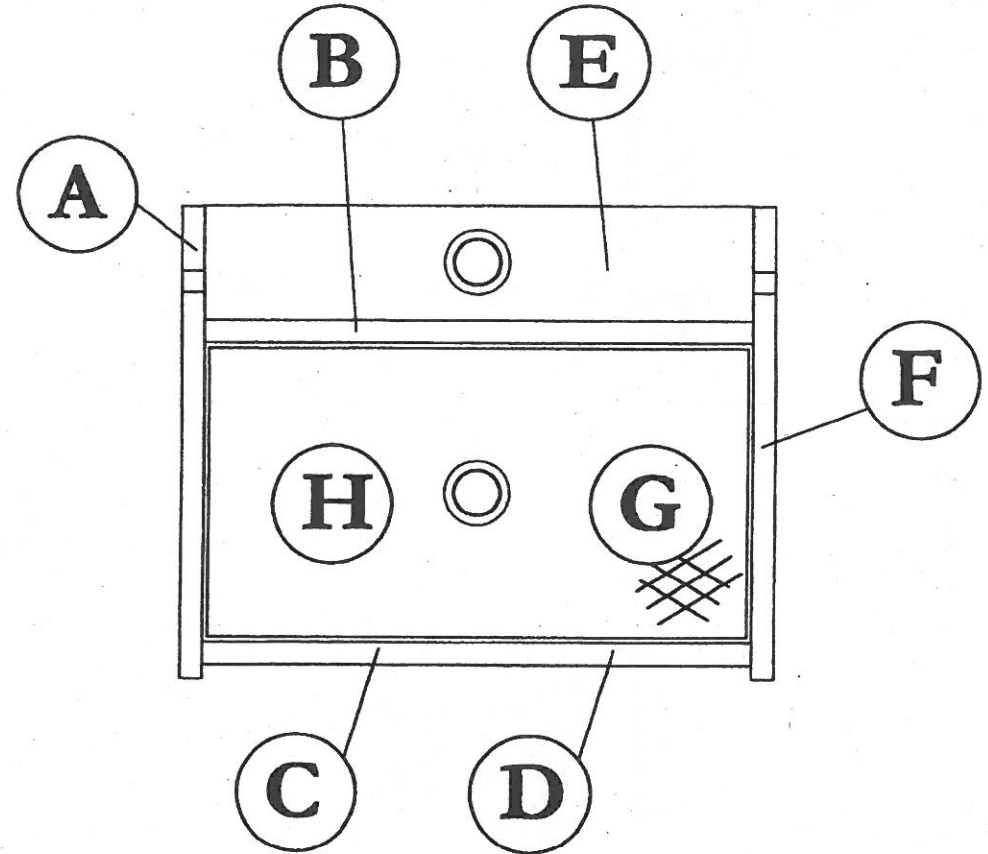

NO	DESCRIPTION	QTY
A	LEFT SIDE	01
B	SHELF	01
C	LOWER SHELF (Front)	01
D	LOWER SHELF (Back)	01

NO	DESCRIPTION	QTY
E	HORIZONTAL SHELF	01
F	RIGHT SIDE	01
G	BACK	01
H	DRAWER FACE	01