

MODEL NAME:

SP 3210-00

1.5hr

APPROXIMATE ASSEMBLY TIME

2 PERSON OF ASSEMBLY

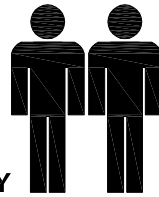

FLOOR AREA
1.5M X 1.5M

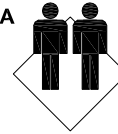

REQUIRED ASSEMBLY SPACE

REQUIRED ASSEMBLY TOOLS

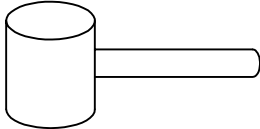

SOFT RUBBER HAMMER

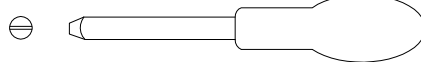

SLOTTED SCREWDRIVER

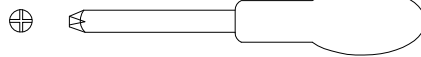

POZI SCREWDRIVER

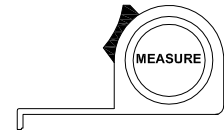

MEASURING TAPE

ASSEMBLED DIMENSIONS

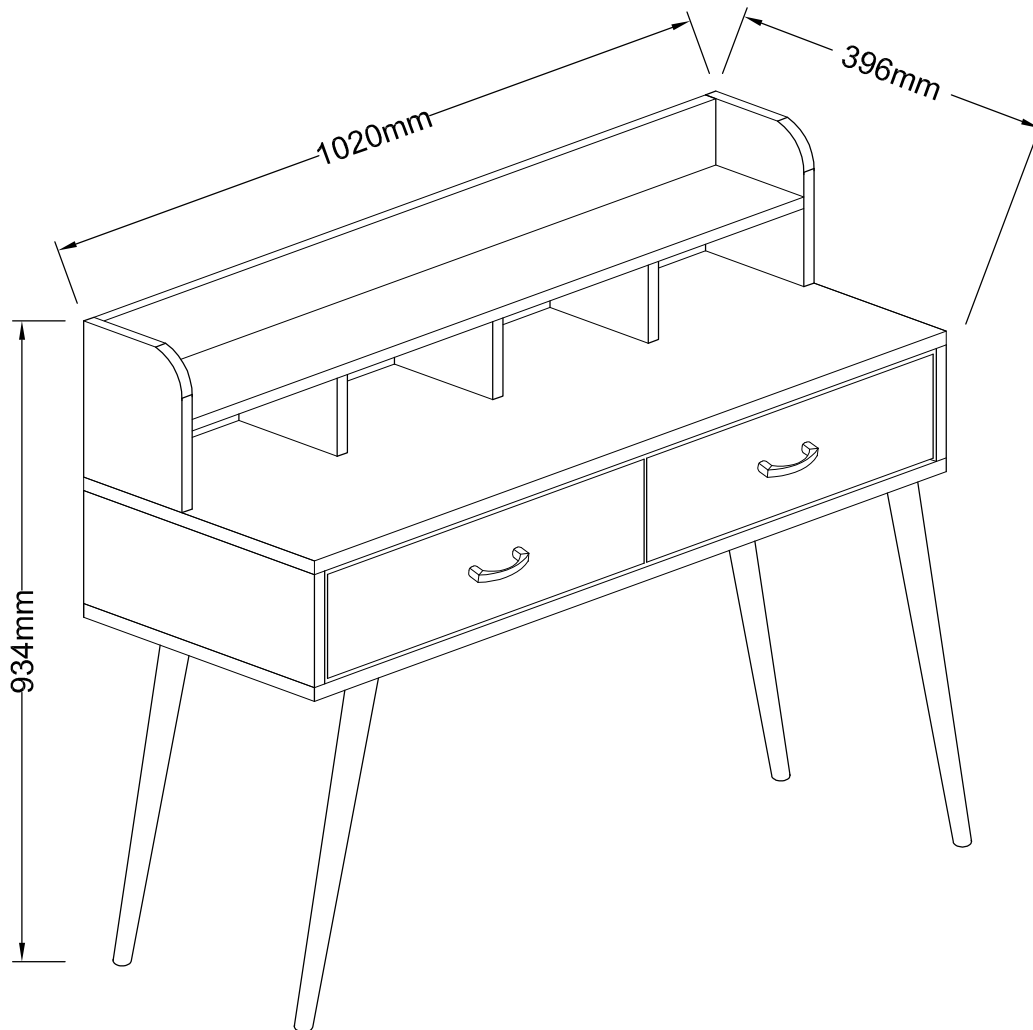

NOTE : THE MAXIMUM WEIGHT THIS PRODUCT CAN HOLD UP TO 25 KGS.

MODEL NAME:

SP 3210-00

NO.	PART LIST	QTY	NO.	PART LIST	QTY
(A)	RIGHT SIDE PANEL	1	(L)	DRAWER FRONT -RIGHT	1
(B)	LEFT SIDE PANEL	1	(M)	DRAWER FRONT -LEFT	1
(C)	CENTRE PANEL	1	(N)	DRAWER RIGHT SIDE PANEL	2
(D)	TOP PANEL	1	(O)	DRAWER LEFT SIDE PANEL	2
(E)	BOTTOM PANEL	1	(P)	DRAWER BACK PANEL	2
(F)	BACK PANEL BOTTOM	1	(Q)	DRAWER BOTTOM SUPPORT	2
(G)	BACK PANEL TOP	1	(R)	DRAWER BASE	2
(H)	TOP RIGHT PANEL	1			
(I)	TOP LEFT PANEL	1			
(J)	TOP CENTRE PANEL	2			
(K)	FIXED PANEL	1			



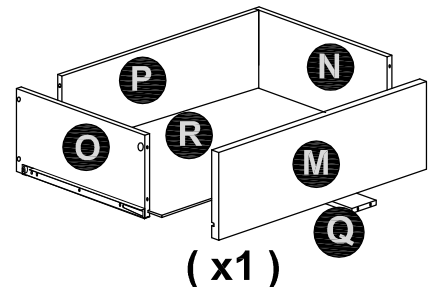
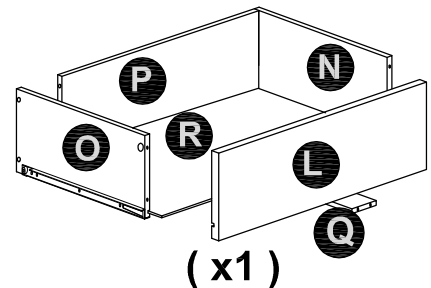
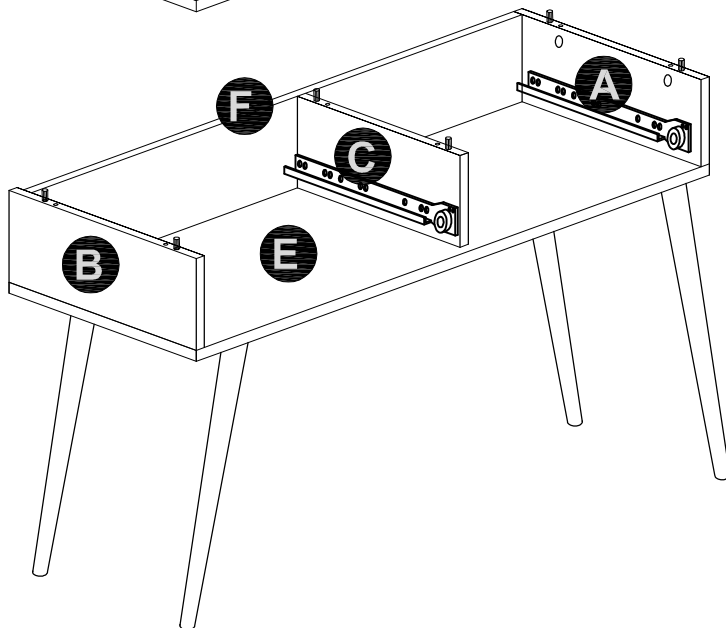
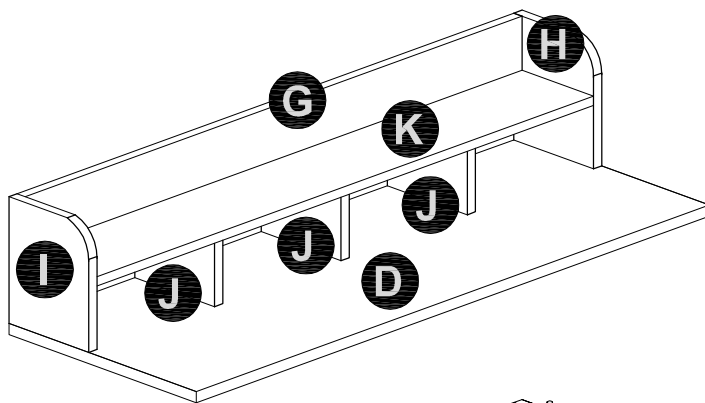







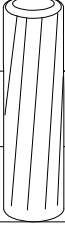
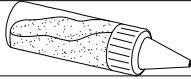
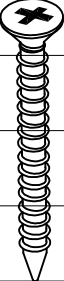
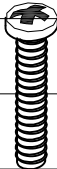

PARTS LIST

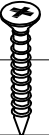
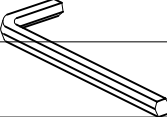

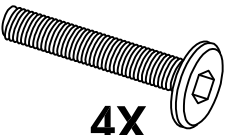
MODEL NAME:

SP 3210-00

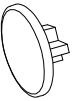
HARDWARE LIST

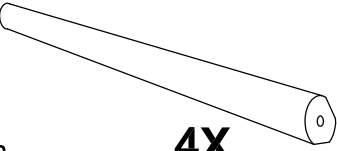
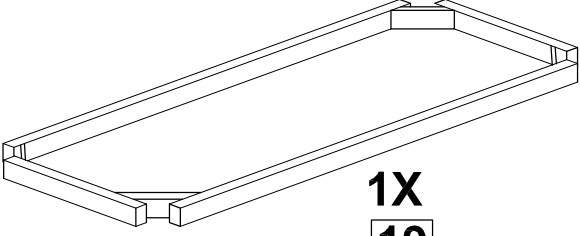
					0cm 1cm 2cm 3cm
12X Dia.15mm 1 LARGE CAMLOCK	4X Dia.15mm 2 SMALL CAMLOCK	16X M6.5 3 QUICKFIT	32X Dia.6 x 30mm 4 WOOD DOWEL	2X 5 GLUE 10CC	
					0cm 1cm 2cm 3cm 4cm
30X M8 x 38mm 6 FLAT HEAD SCREW	4X M4 x 19mm 7 PAN HEAD SCREW	12X M3.5 x 25mm 8 FLAT HEAD SCREW	10X M4 x 30mm 9 FLAT HEAD SCREW	1X M5 10 ALLEN KEY	
					
2X 11 HANDLE	4X M8 x 70mm 12 ALLEN HEAD BOLT	4X 5/16 13 SPRING WASHER	4X 22 x 5/16 14 FLAT WASHER	2X 15 ANTI TIP STRAP	
					
6X Dia 17mm 16 UNIVERSAL CAP SCREW COVER (OPTIONAL)	6X Dia.13mm 17 SCREW COVER (OPTIONAL)	4X 18 Dia.45/27- 610mm LEG	1X 19 WOODEN FRAME		

MODEL NAME:

SP 3210-00

Top Tips before you start!

1. Please check that all parts are present before you start the assembly of your furniture.
2. For ease and speed of assembly, we recommend that before you commence each step of the assembly, that you identify all the parts required for that step.
3. For larger items, please ensure that you have sufficient space and people (as indicated on page 1) to assemble your product safely
4. We recommend that, where possible, all items are assembled near to the area in which they will be placed in use, to avoid moving the product unnecessarily once assembled.
5. For the protection of your furniture, particularly items of high gloss finish, we recommend that the product is placed on a protected surface during assembly to prevent any damage.
6. Caution - Electric / Battery operated screw driver NOT RECOMMENDED.
7. During assembly please take care not to over-tighten any fittings, as this may damage the product.
8. Always place the product on a flat, steady and stable surface.
9. Do not sit or stand on the product.
Do not use the product as a stepladder.
10. This product is intended for indoor, household use only as it is non industrial product.
11. This product is constructed from re-inforced hollow board. Excessive pressure cause irreparable damage. Please do not kneel on any part of this product during assembly.

Care and Maintenance of your Furniture

- Please periodically check all fittings and re-tighten as necessary.
- To clean your item, please use a damp cloth and wipe clean.
- Never allow any kind of liquid to remain on your furniture.
- Please do not place hot items (e.g. hot drinks) directly on to the wood surface.
- Please do not drag and pull your furniture.

MODEL NAME:

SP 3210-00

SPECIAL TIPS FOR FITTING CAM-LOCKS AND QUICKFIT

LARGE CAM-LOCK

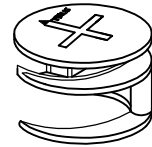

WHEN FITTING CAMLOCK
ENSURE STARTING POSITION IS CORRECT
BEFORE YOU INSERT CONNECTING QUICKFIT
TURN CLOCKWISE UNTIL SECURE

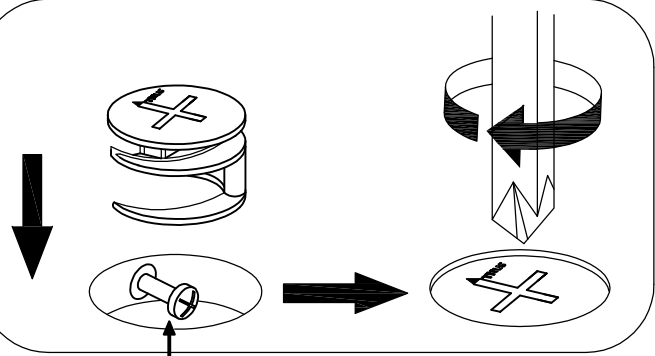
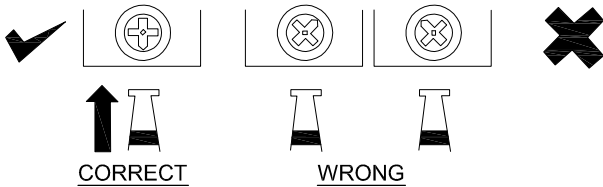

Quickfit head needs to be in centre

SMALL CAM-LOCK

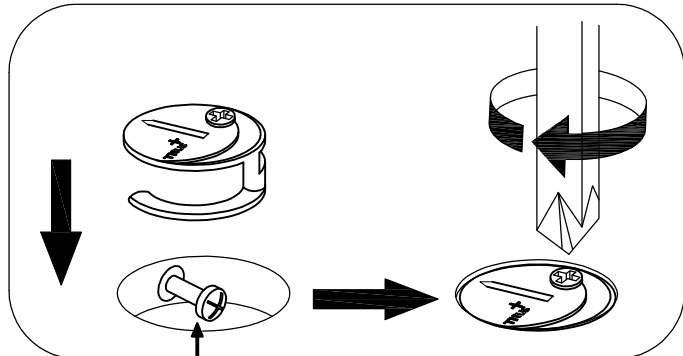

Quickfit head needs to be in centre

QUICKFIT

Tighten until shoulder is flush with panel. Do not overtighten or undertighten (see example below)

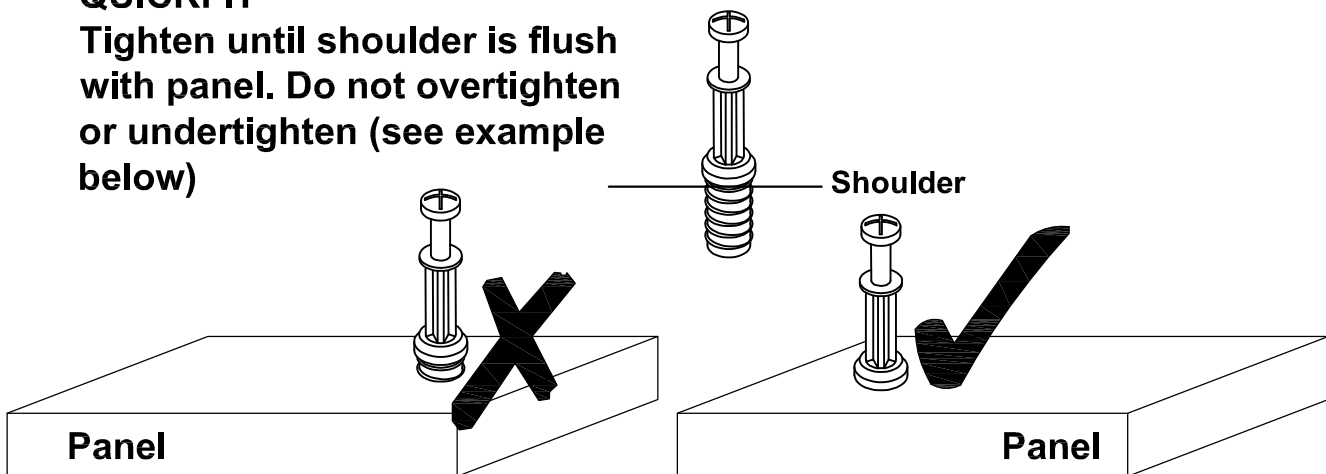

MODEL NAME:

SP 3210-00

STEP 1

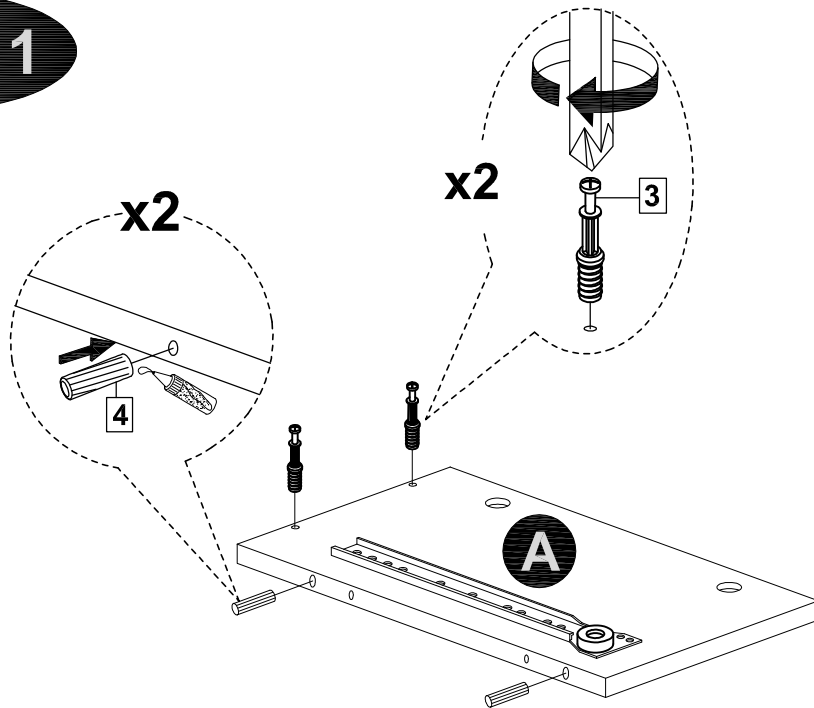

STEP 2

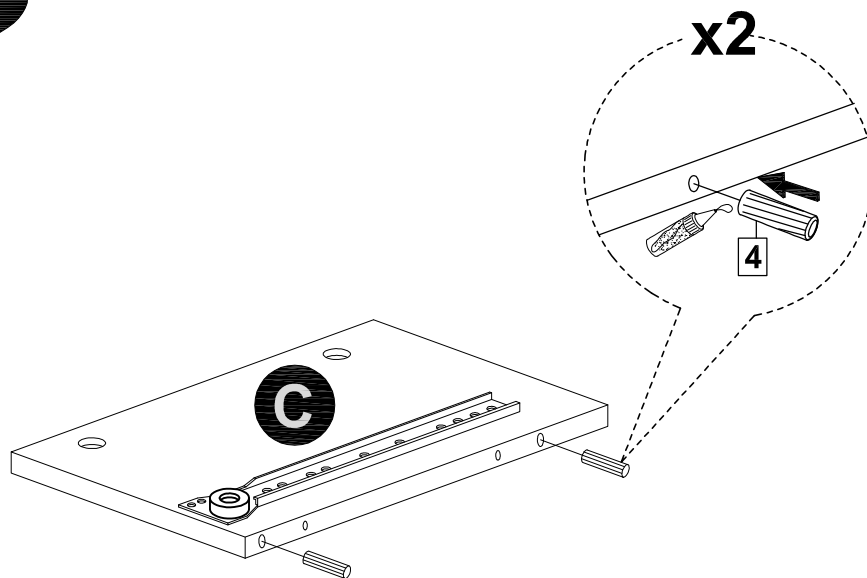

MODEL NAME:

SP 3210-00

STEP 3

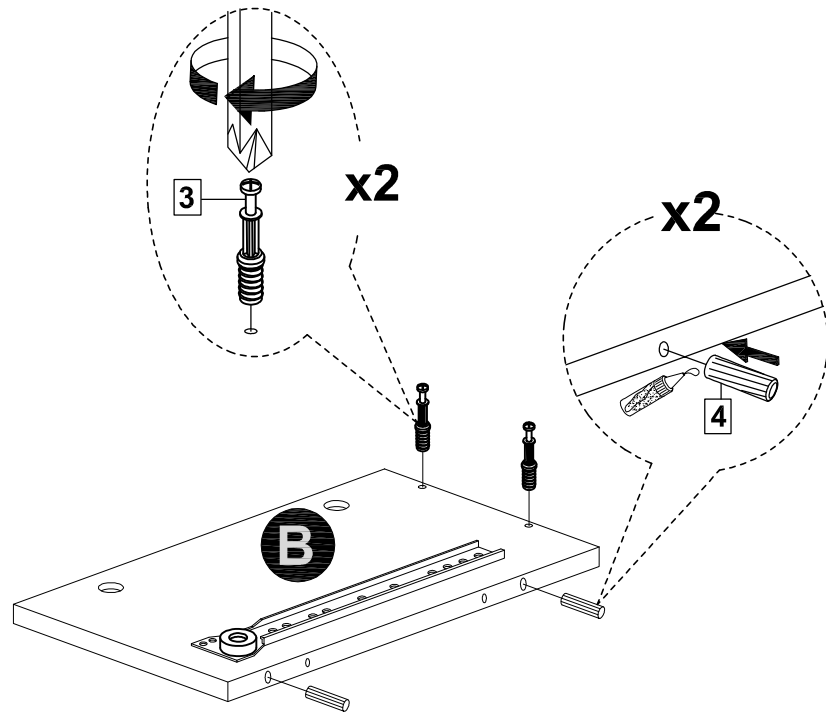

STEP 4

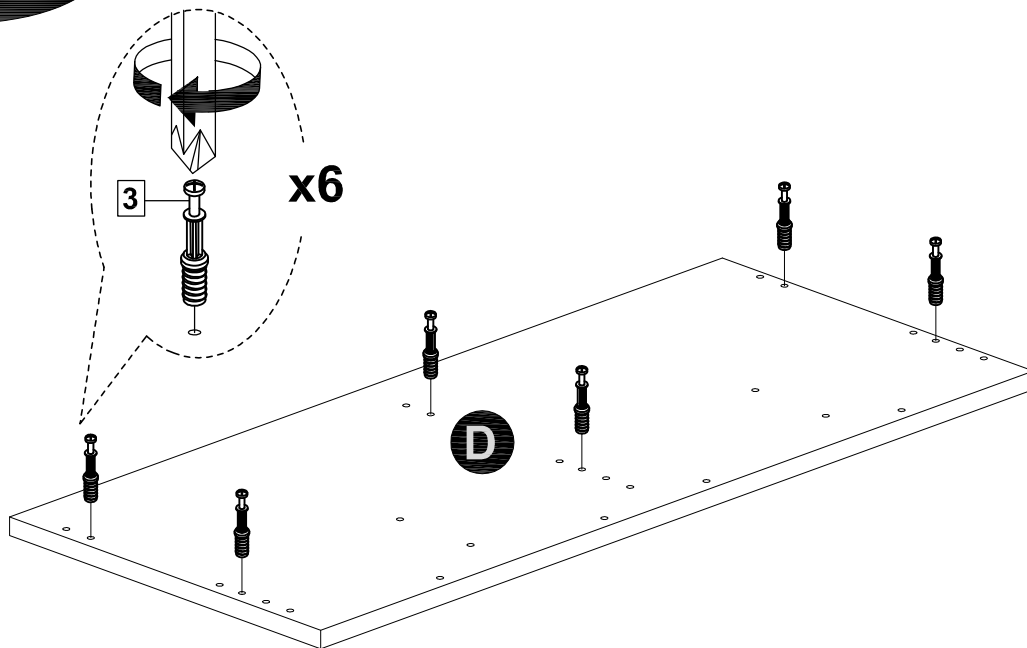

MODEL NAME:

SP 3210-00

STEP 5

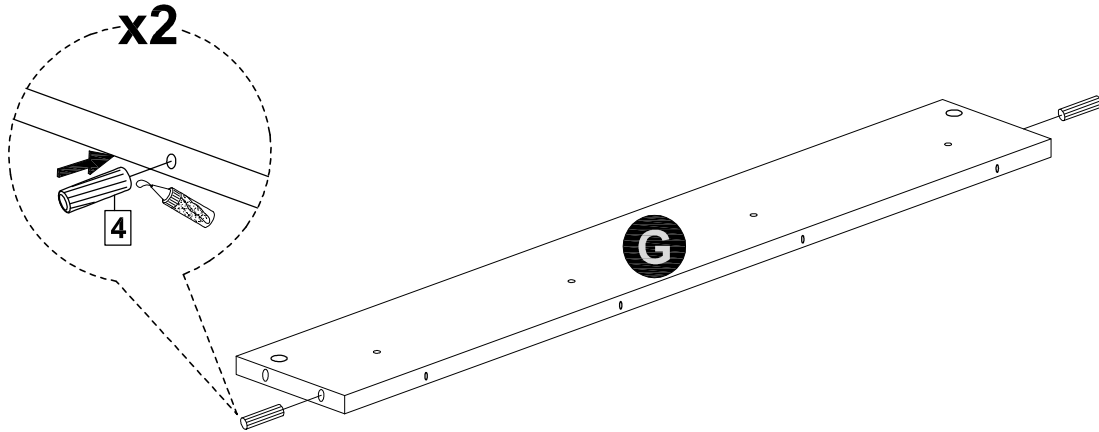

STEP 6

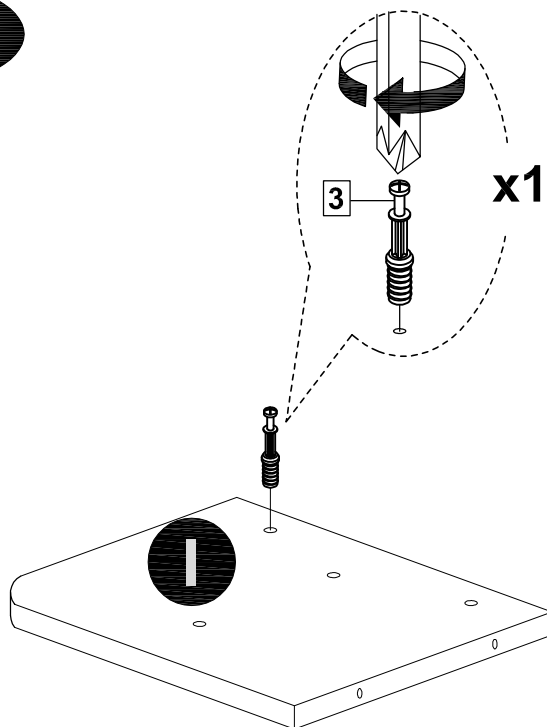

MODEL NAME:

SP 3210-00

STEP 7

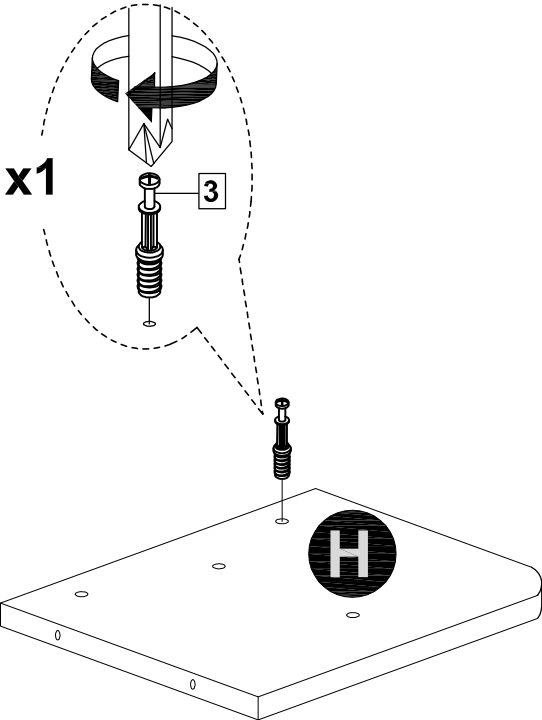

STEP 8

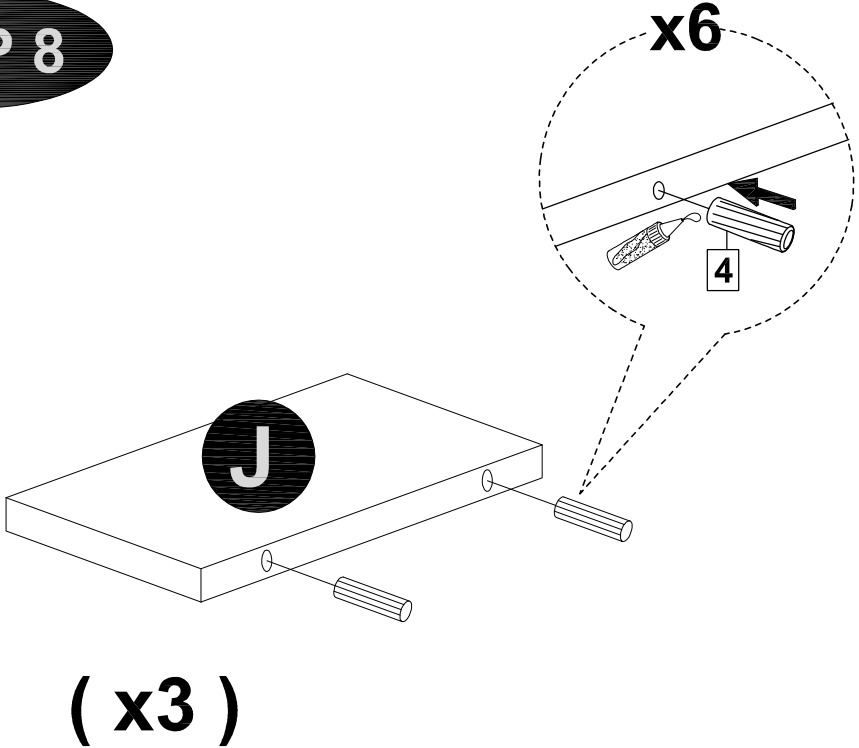

MODEL NAME:

SP 3210-00

STEP 9

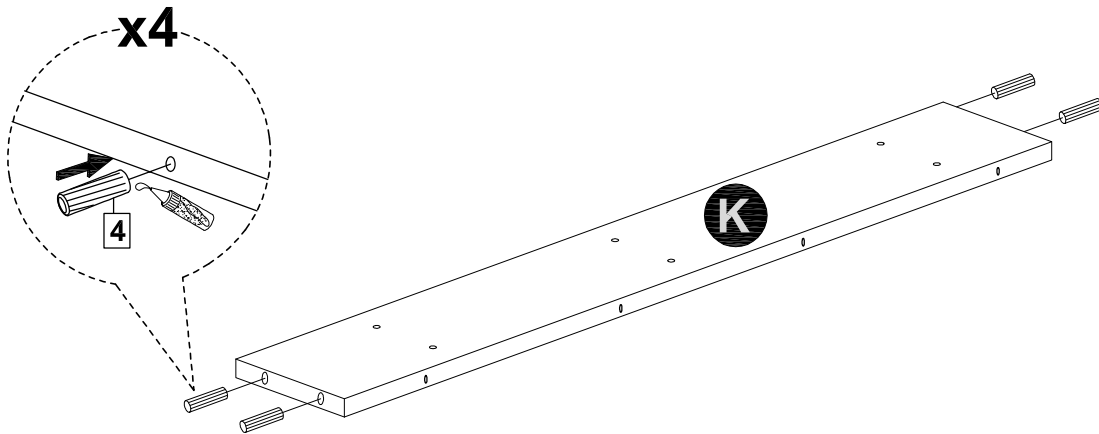

STEP 10

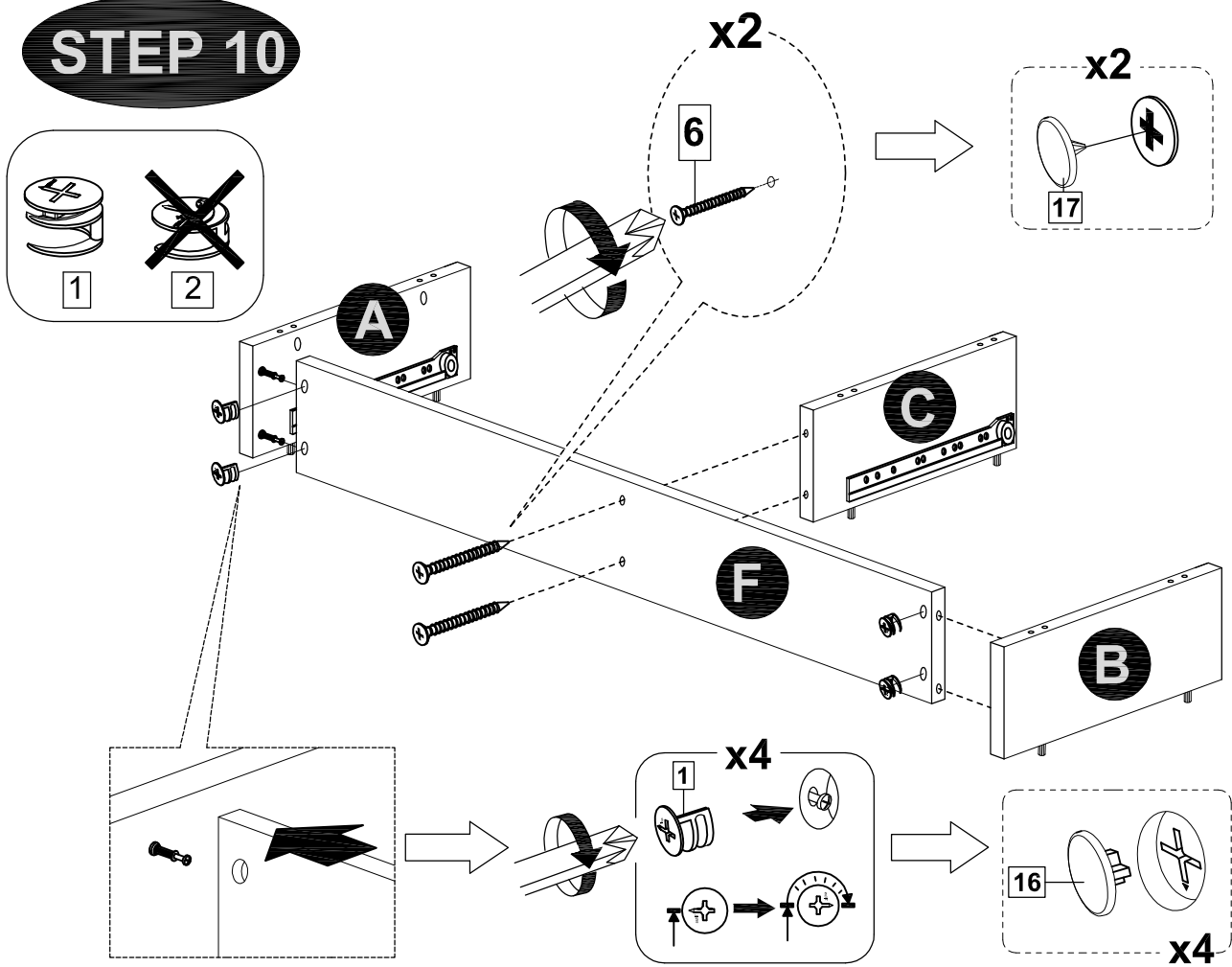

MODEL NAME:

SP 3210-00

STEP 11

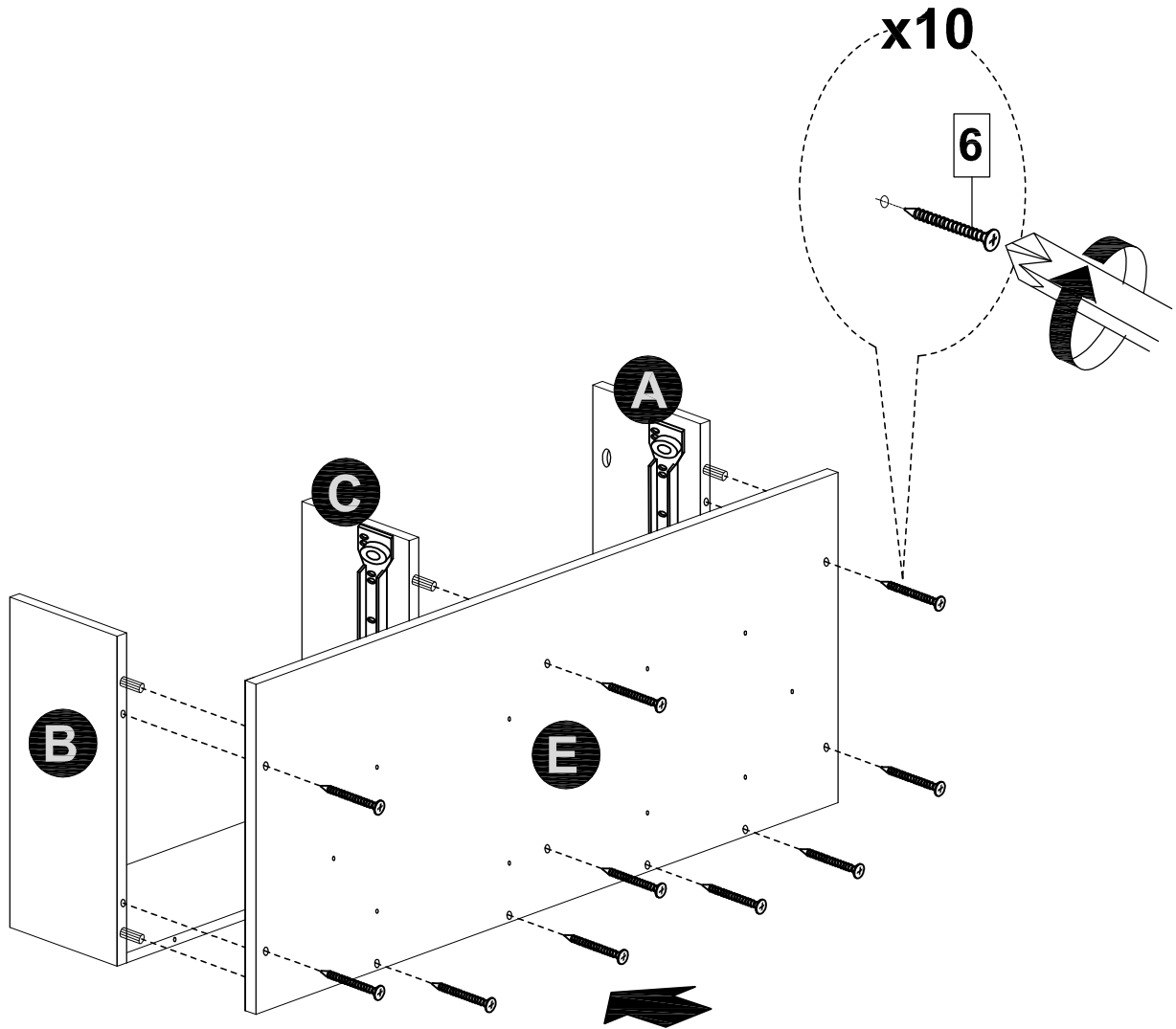

MODEL NAME:

SP 3210-00

STEP 12

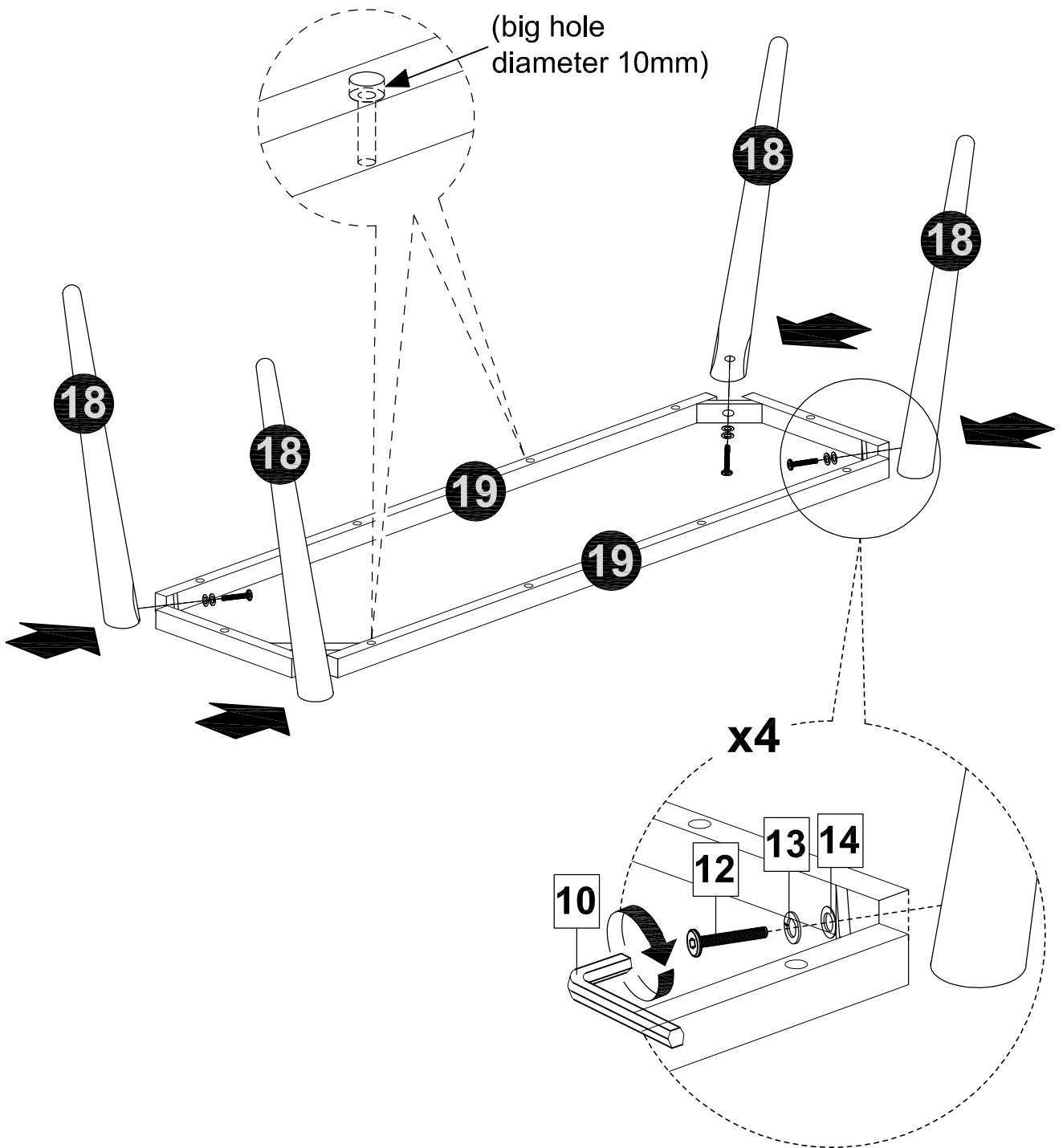

MODEL NAME:

SP 3210-00

STEP 13

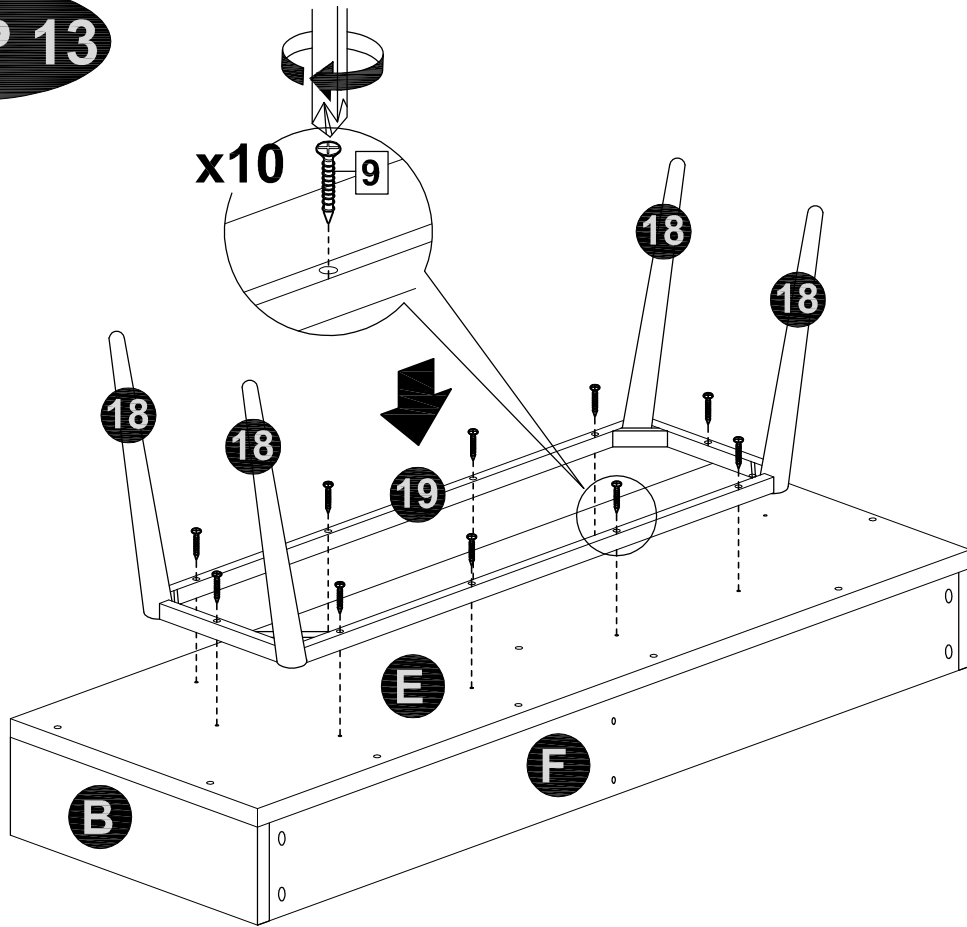

STEP 14

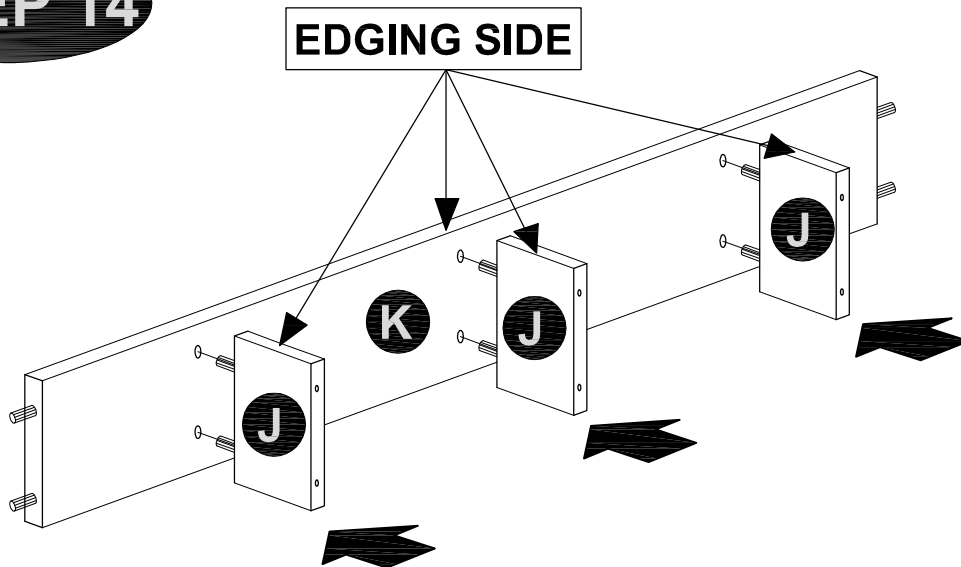

MODEL NAME:

SP 3210-00

STEP 15

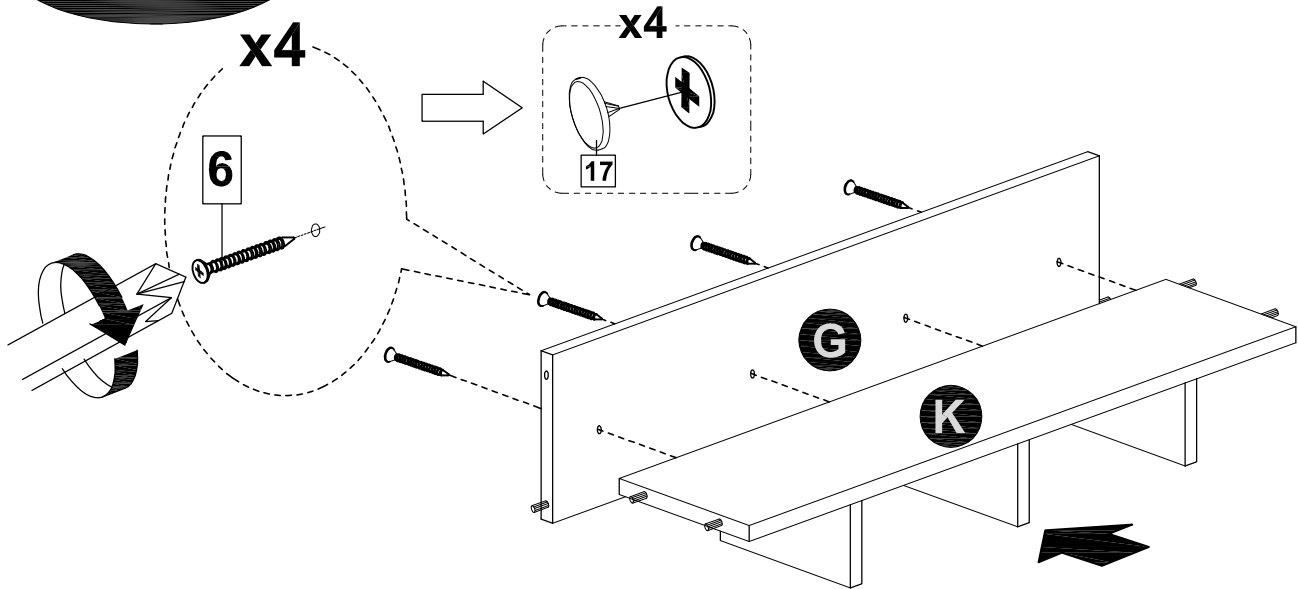

STEP 16

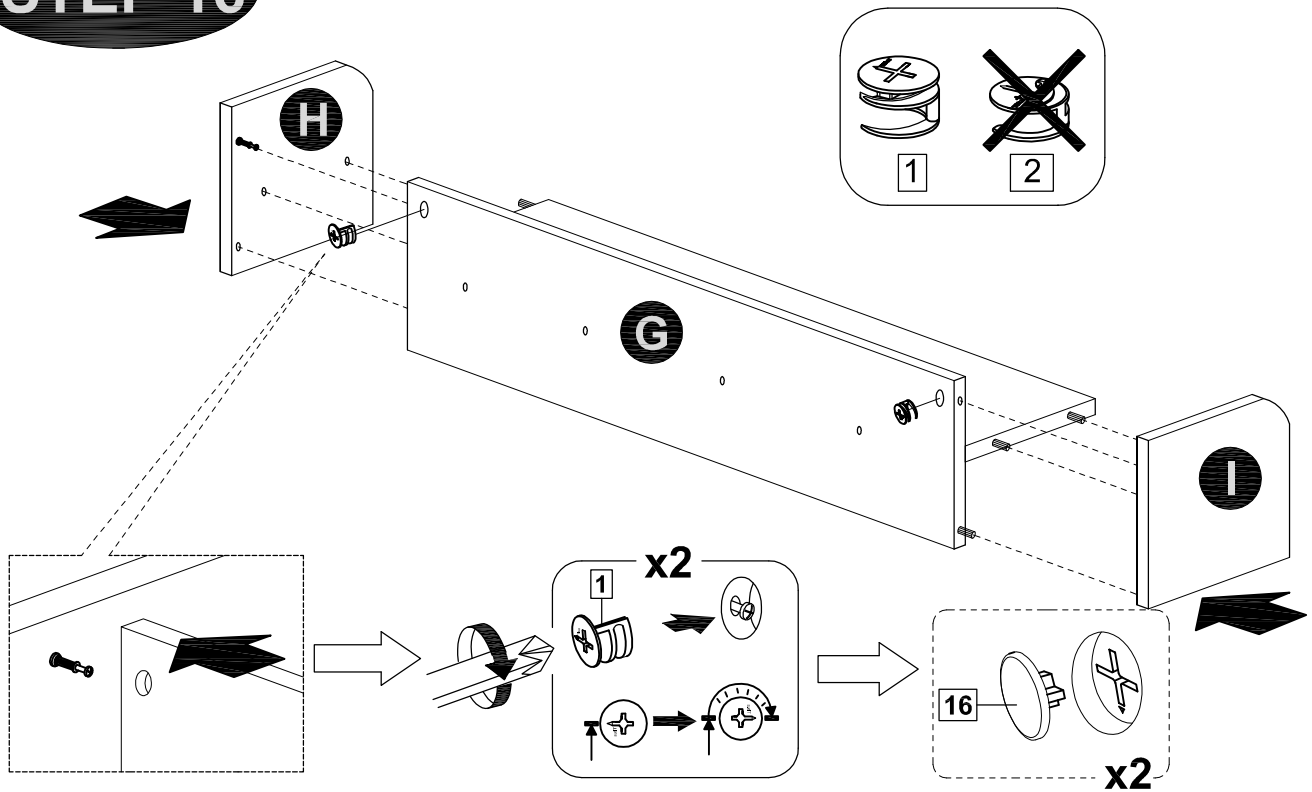

MODEL NAME:

SP 3210-00

STEP 17

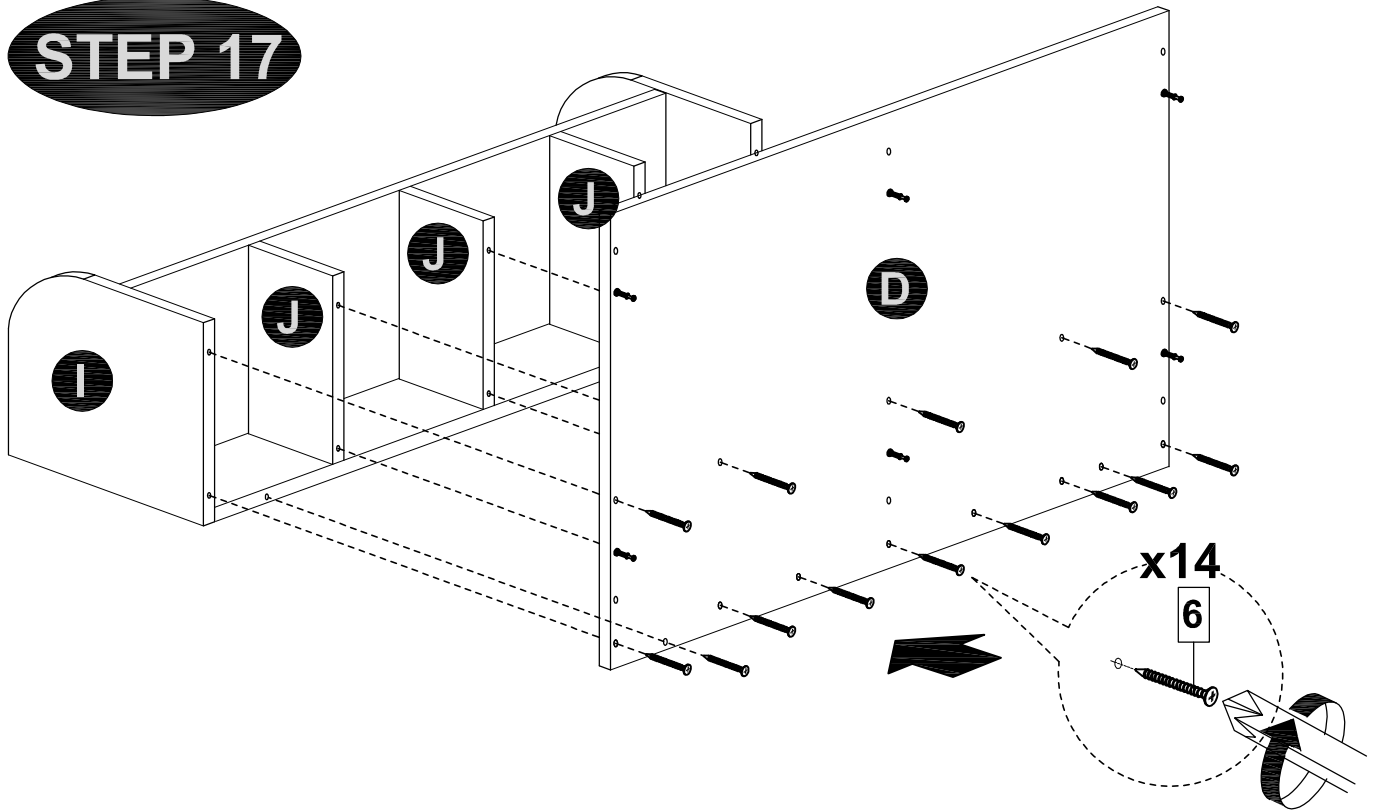

STEP 18

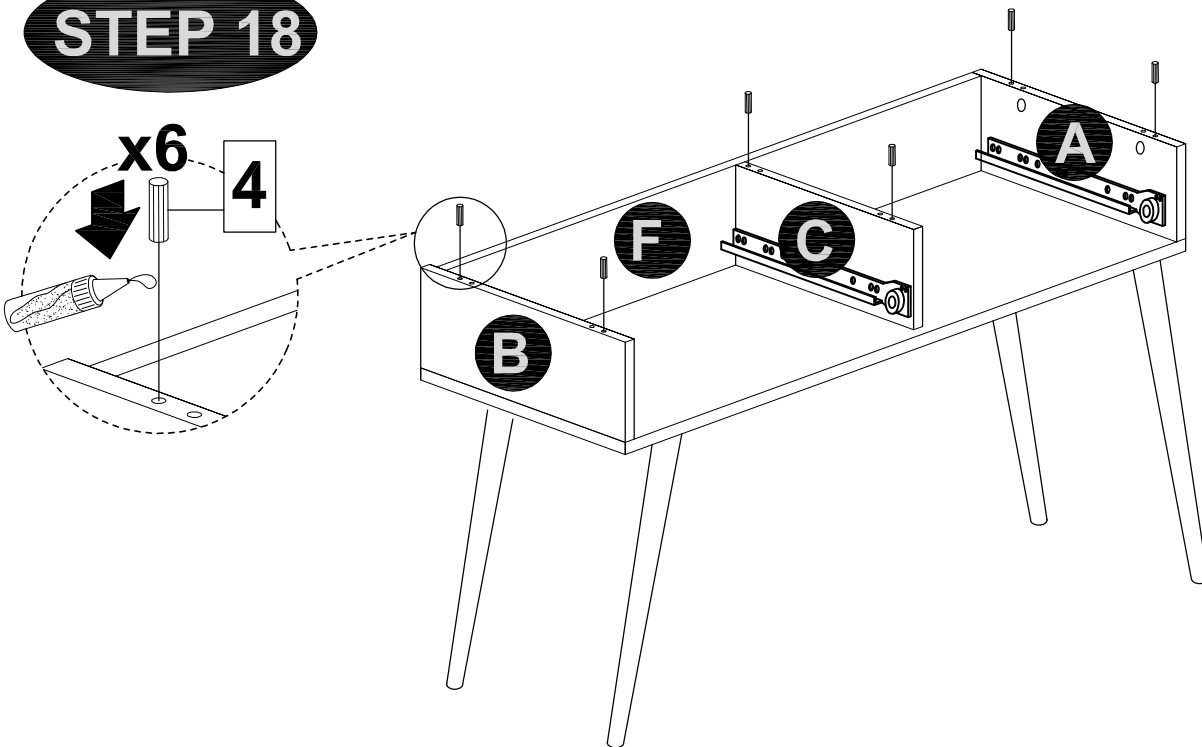

MODEL NAME:

SP 3210-00

STEP 19

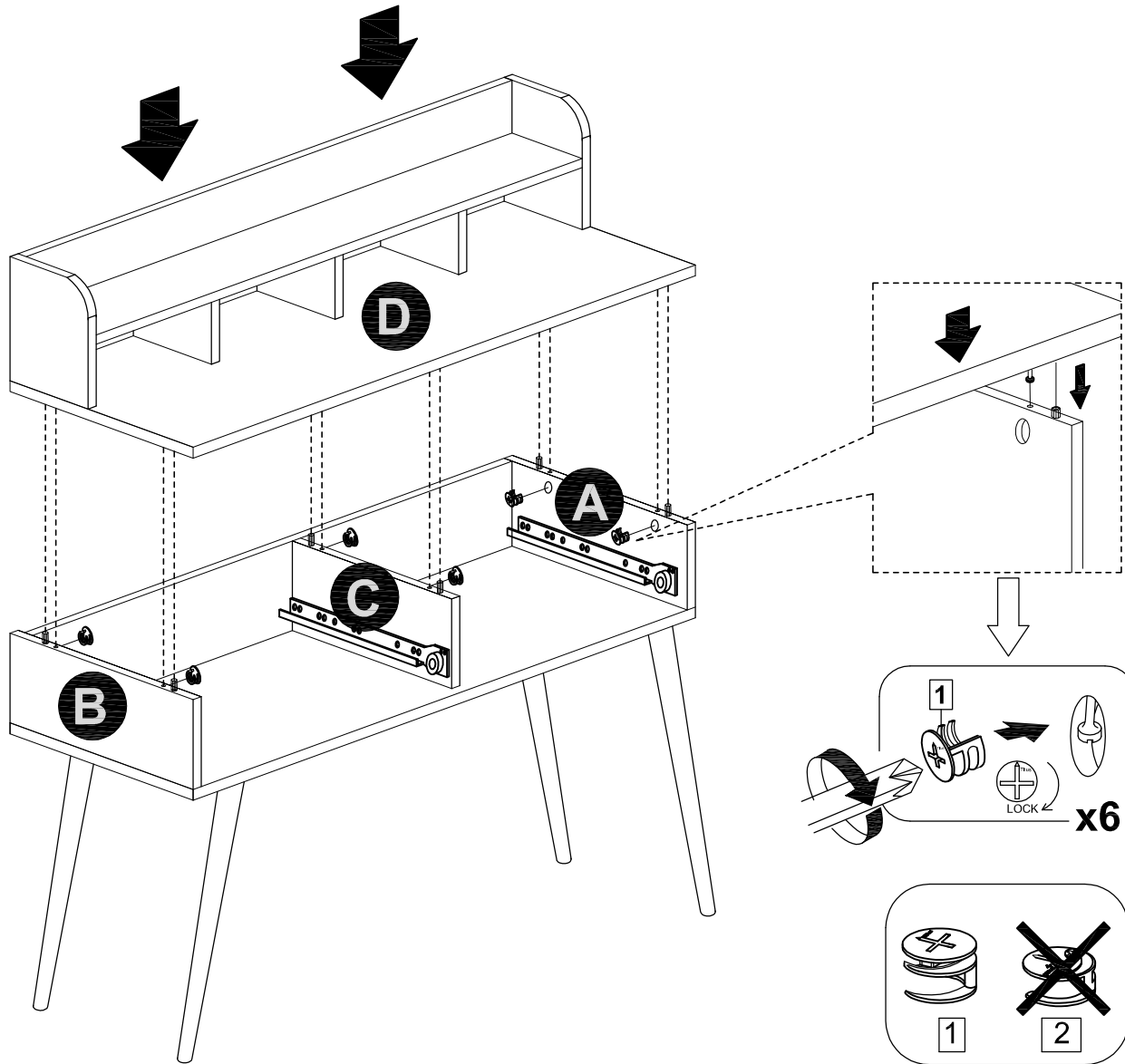

MODEL NAME:

SP 3210-00

STEP 20

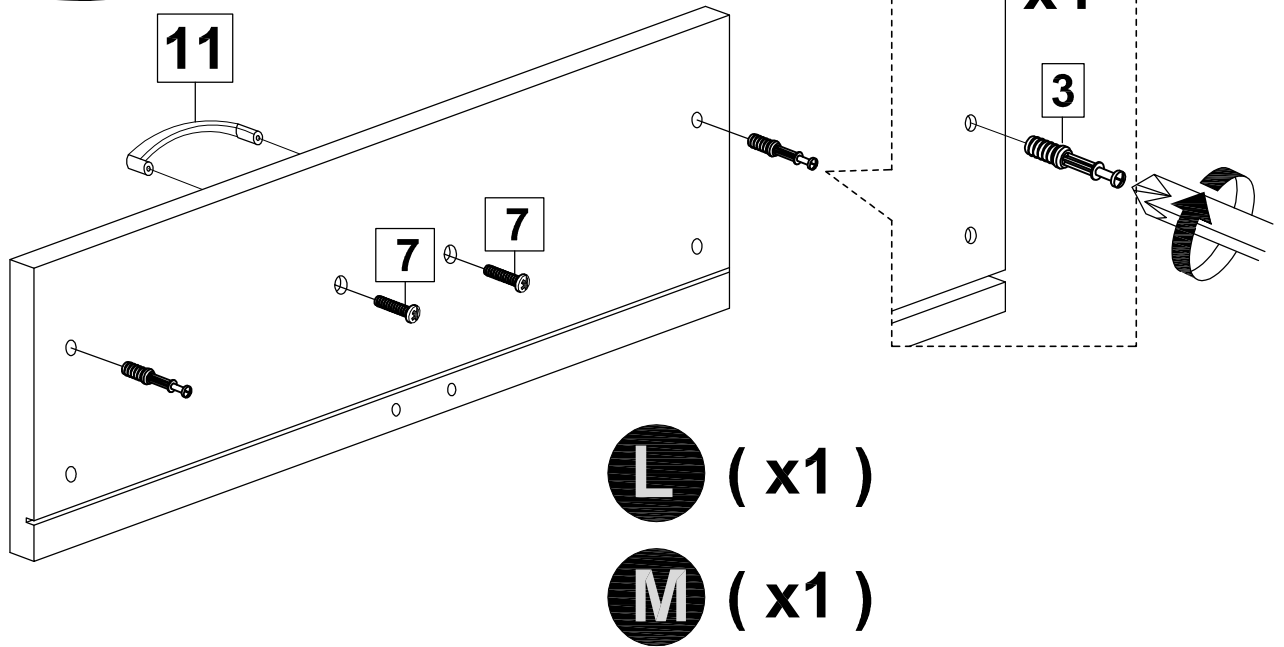

STEP 21

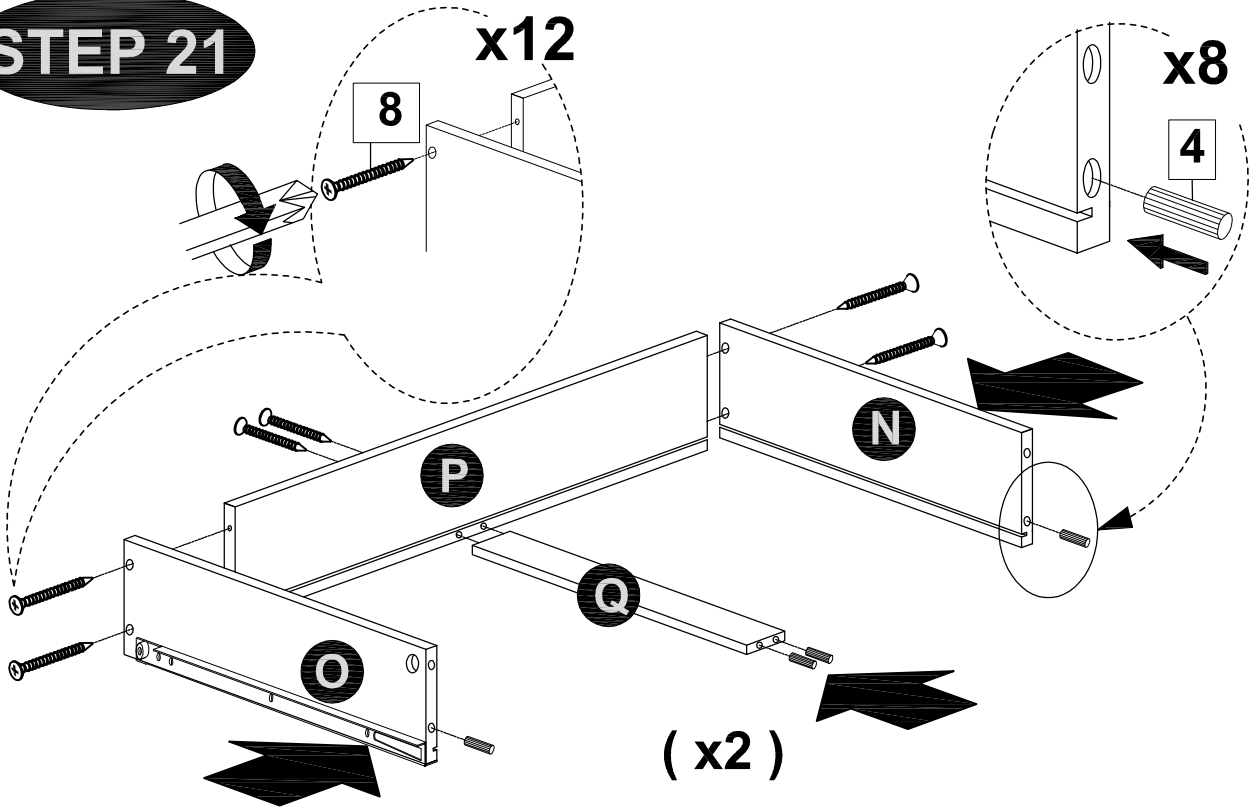

MODEL NAME:

SP 3210-00

STEP 22

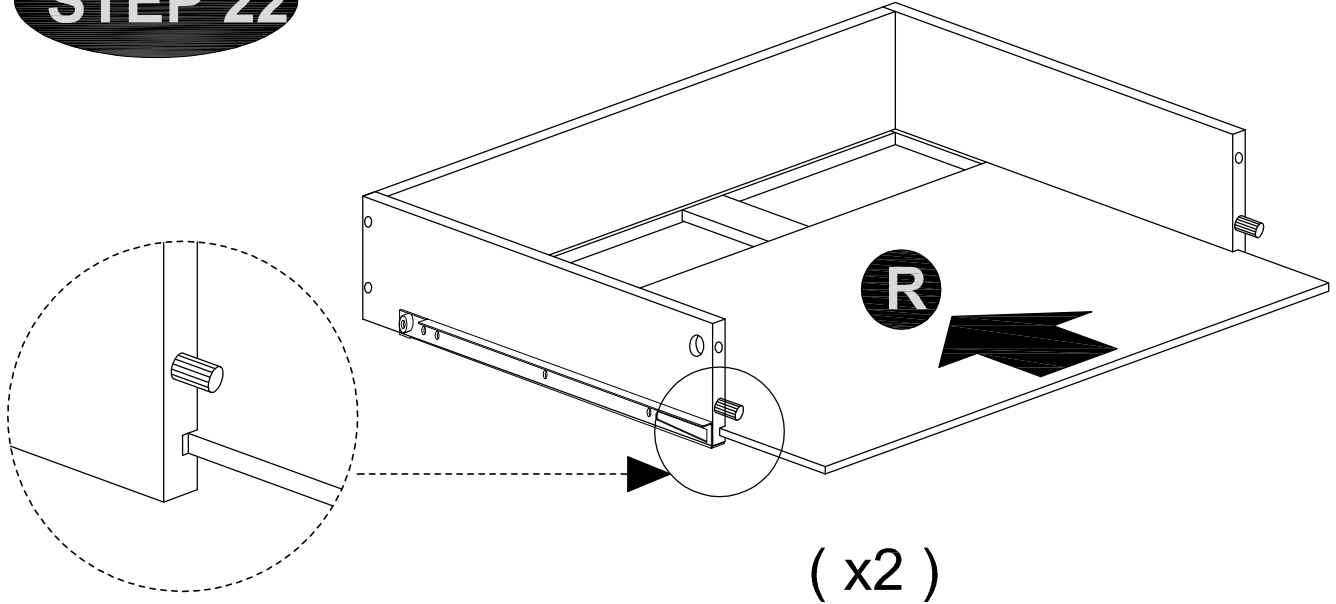

STEP 23

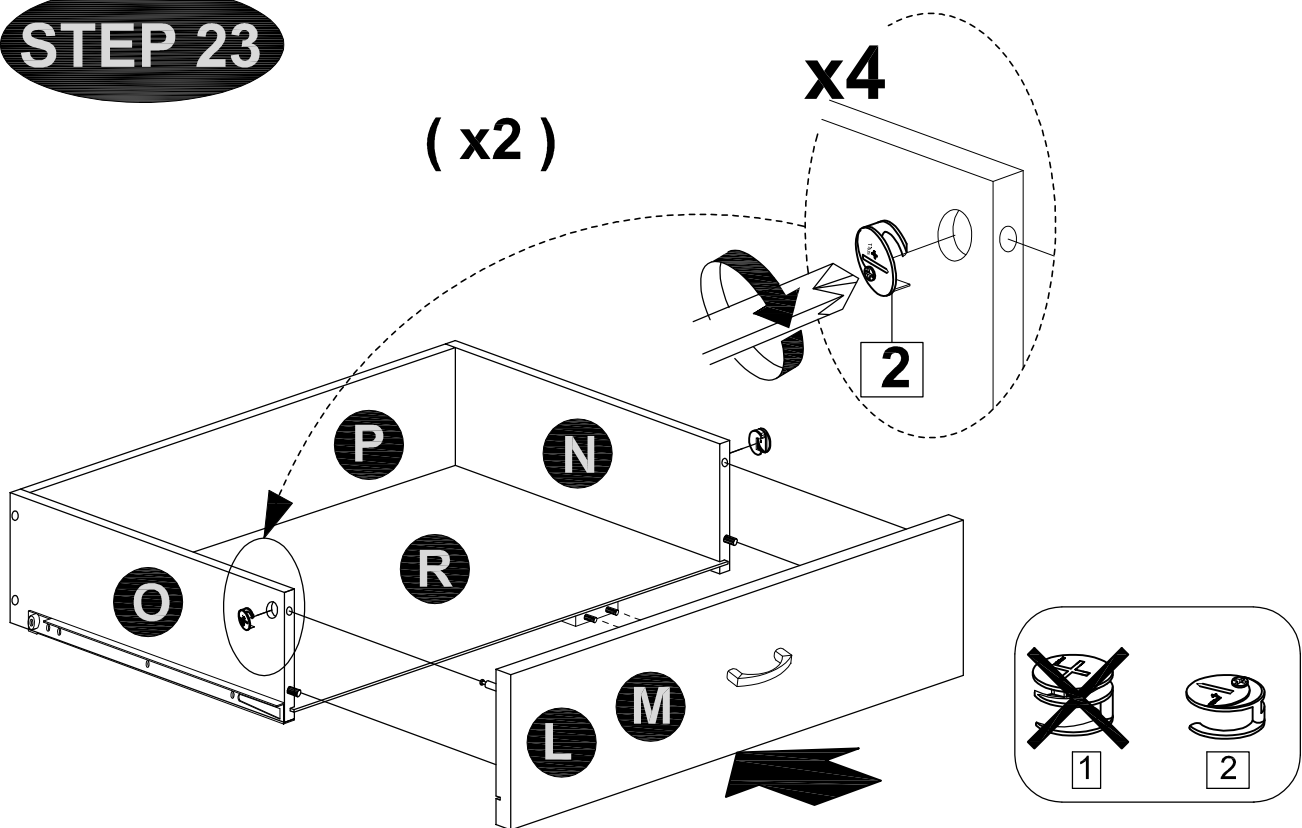

MODEL NAME:

SP 3210-00

STEP 24

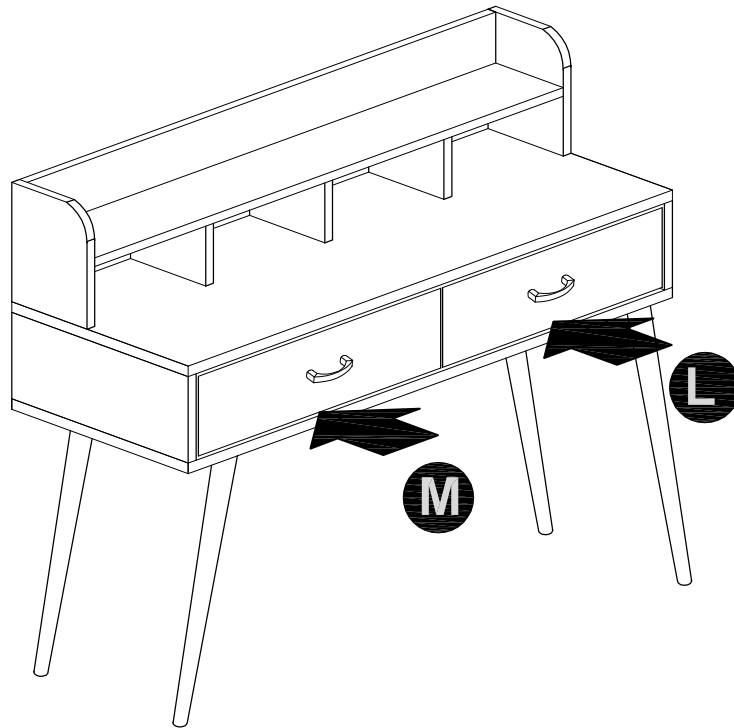

STEP 25

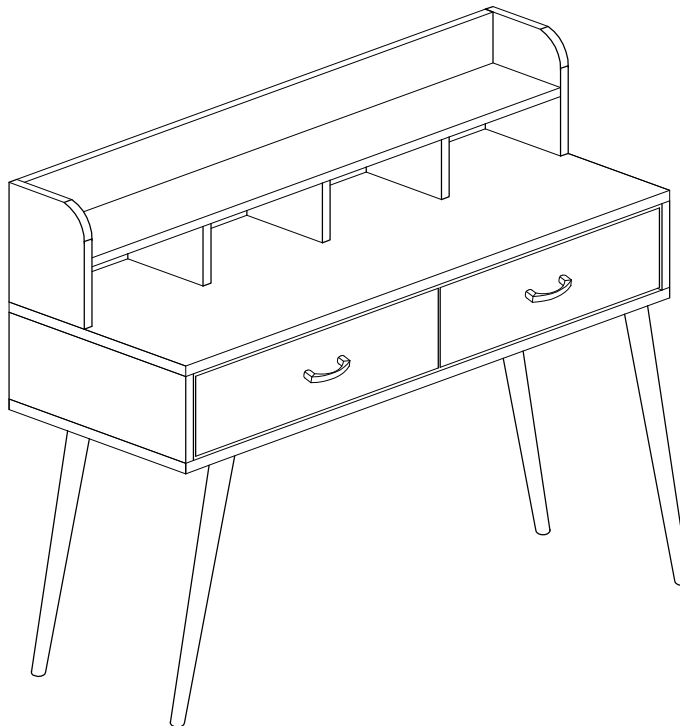

SAFETY WARNING :

It is recommended that you fit the anti-tip bracket to this item to avoid tipping and causing injury.

FITTING OF ANTI-TIP BRACKET

STEP 1 :

Insert screws through bracket into pre-drilled holes in cabinet.

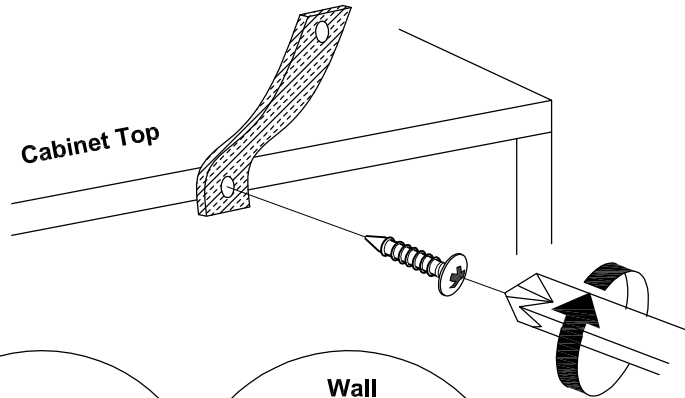

STEP 2 :

Make a mark on the wall through the bracket.

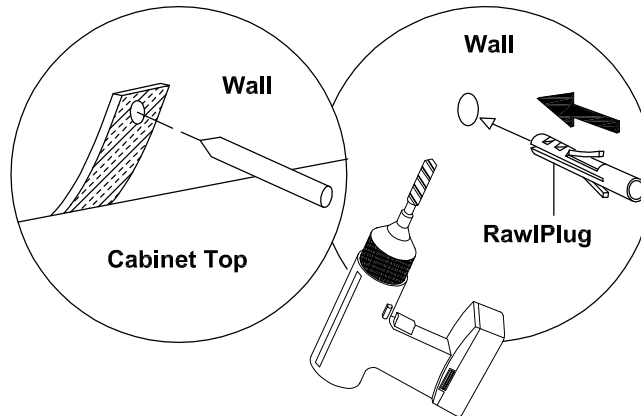

Drill a hole in the wall and insert the rawlplug.

STEP 3 :

Insert screw through bracket into hole in wall

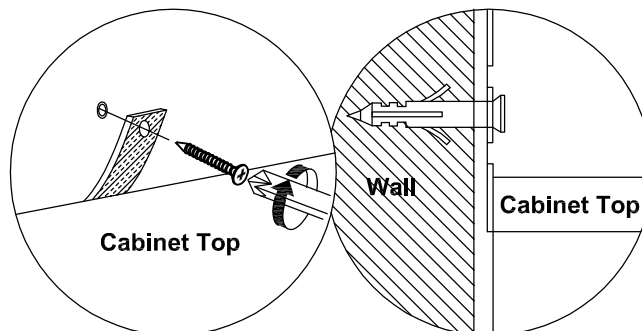

NOTE : Wall fixings are not supplied with this product as different wall materials require different types of fixing devices (such as Rawl plugs on brick work). You must use fixing devices suitable for the type of wall you intend to mount this product to. Please ensure that the head of any screw used has a diameter greater than the diameter of the mounting hole on the bracket and that the fixing is safe and secure before use.

The screw supplied is to fix the anti-tip strap to the cabinet.

HARDWARE LIST



Anti-Tip Strap - 2pcs



M4 x 16MM - 2pcs