

ASSEMBLY INSTRUCTION
MODEL : 5013 / SIDE TABLE

Before you begin, please follow assembly instruction carefully.
 Then follow them step by step.

STEP 1

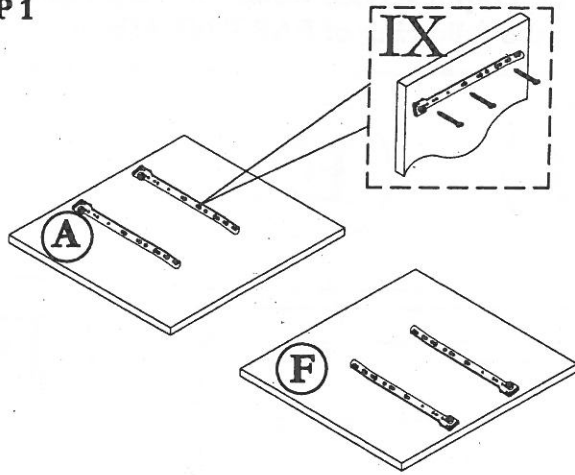

STEP 2

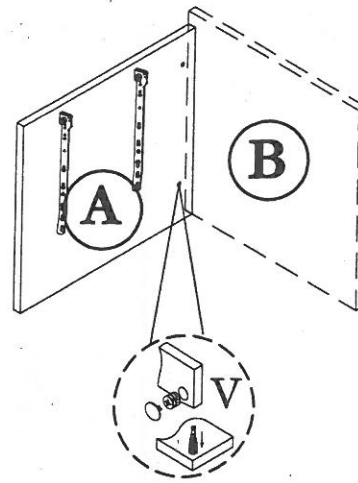

STEP 3

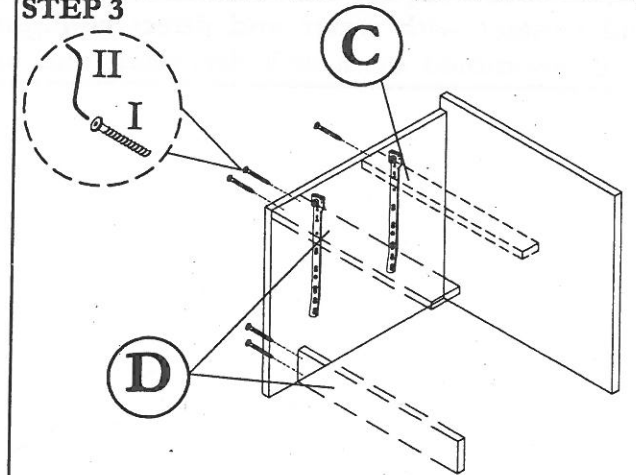

STEP 4

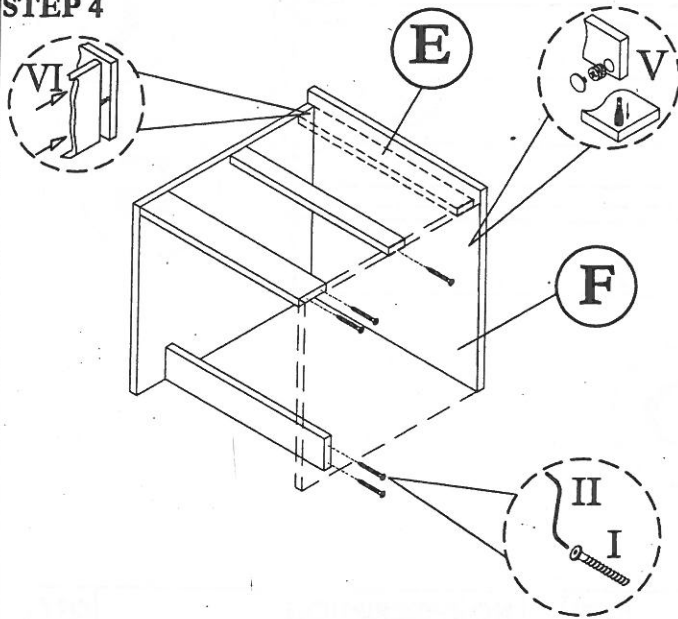

STEP 5

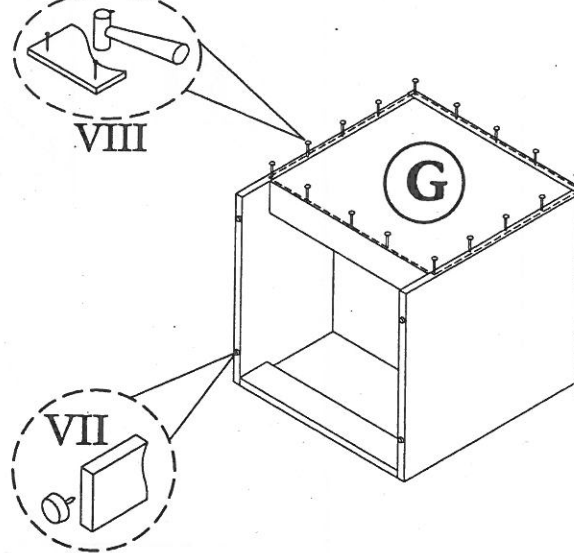

STEP 6

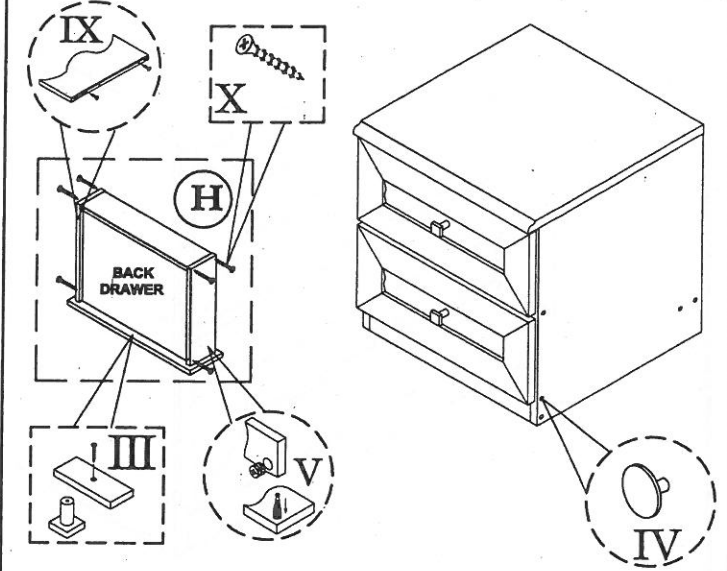

HARDWARE LIST

NO	DESCRIPTION	QTY
I	JCBCW SCREW M6 x 45	10pcs
II	M4 ALLEN KEY	1pc
III	HANDLE & SCREW M4 x 25	2sets

IV	CAP SMALL	10pcs
V	Q-FIT	12sets
VI	M8 x 30 PLASTIC DOWEL	2pcs
VII	PVC NAIL WITH PIN	4pcs
VIII	NAIL	20pcs

IX	DRAWER SLIDER & SCREW M3.5 x 12	2sets
X	M8 X 32 CHIPBOARD SCREW	12pcs

CAUTION:

To clean use soft, dry cloth. Do not use detergent or chemicals
Avoid contact with water and direct sunlight.
To be assembled on a soft, dry, clean and smooth surface.

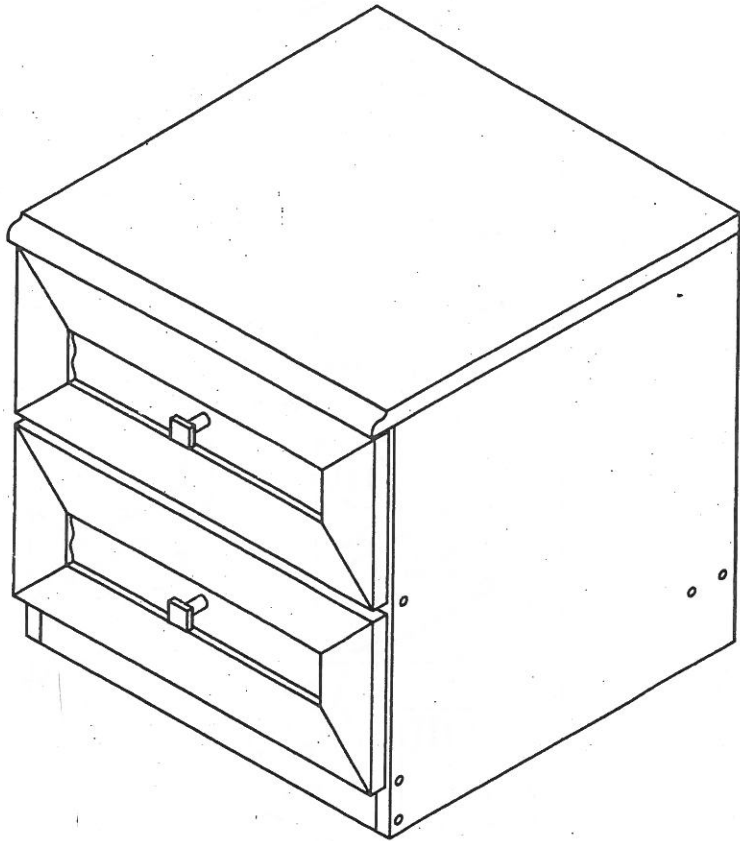

ORDERING REPAIR PARTS

In order to obtain smooth and rapid service when ordering repair parts, please give full attention to the following of PART NUMBER.

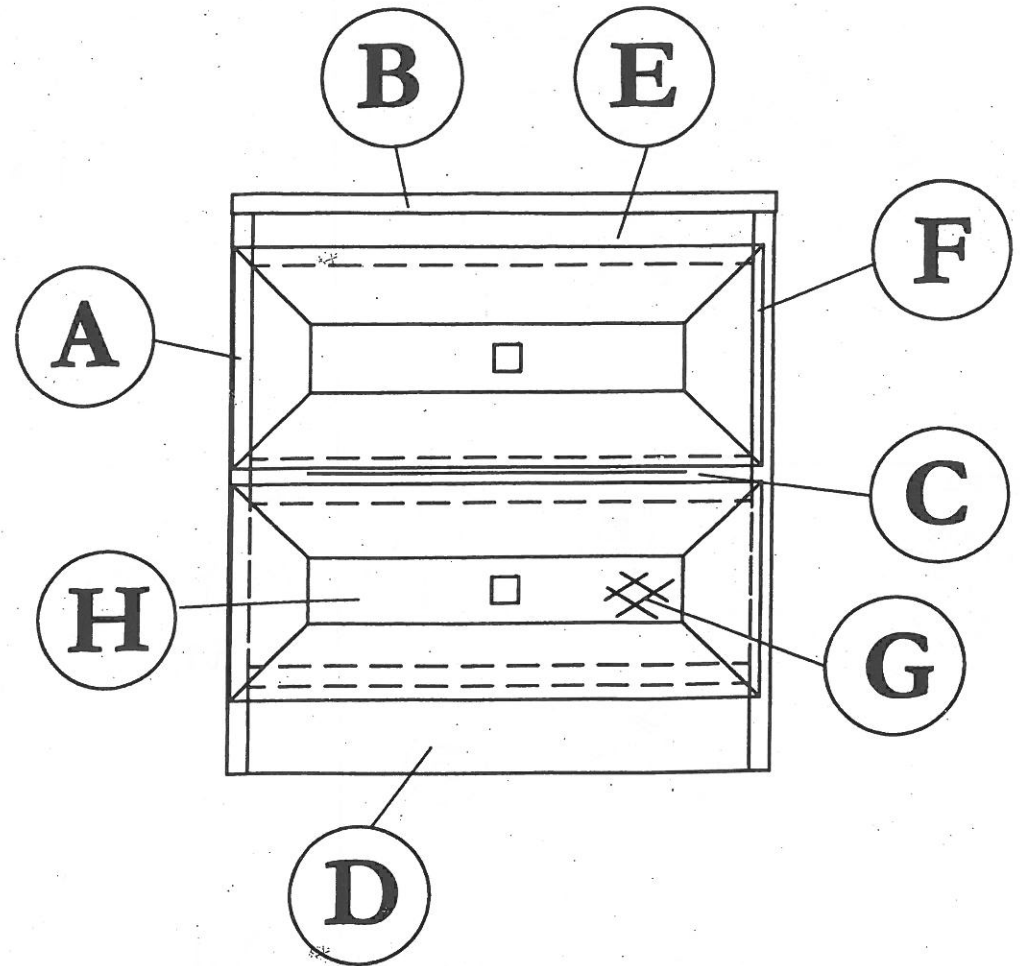

NO	DESCRIPTION	QTY
A	LEFT SIDE	01
B	TOP	01
C	CENTRE SUPPORT	01
D	LEG	02

NO	DESCRIPTION	QTY
E	TOP SUPPORT	01
F	RIGHT SIDE	01
G	BACK	01
H	DRAWER FACE	02

COMPLETE SET