

ASSEMBLY INSTRUCTIONS

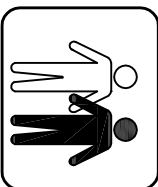
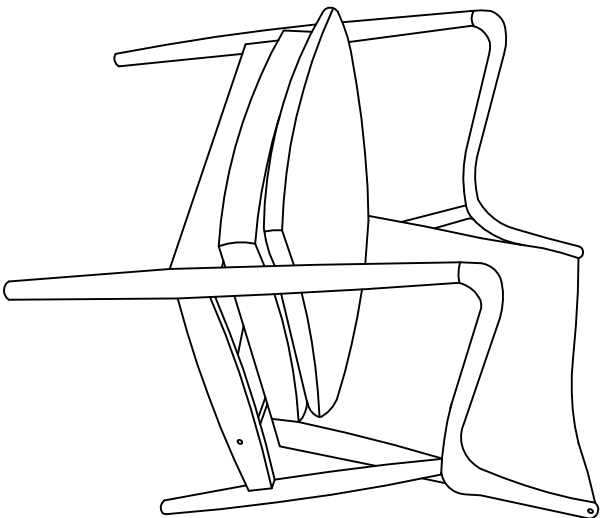

2 PEOPLE REQUIRED

ASSEMBLY TIPS

1. Remove hardware from box and sort by size.
2. Please check to see that all hardware and parts are present prior start of assembly.
3. Please follow attached instructions in the same sequence as numbered to assure fast and easy assembly.
4. Estimated 45 minutes required for assembly.



Warning !

1. Don't attempt to repair or modify parts that are broken or defective. Please contact the store immediately.
2. This product is for home use only and not intended for commercial establishments.

HARDWARE LIST

1		2 PCS	5		4 PCS
JCBC	M6 x 40mm	7 PCS	6	WOODEN CAP	1 PC
2					
JCBC	M6 x 50mm	4 PCS	7	ALLEN KEY (M4)	3 PCS
3					
WOOD SCREW	4.0 x 50mm	7 PCS	8	FLAT WASHER	3 PCS
4					
WOOD DOWEL	Ø10 x 30mm	9	9	SPRING WASHER	2 PCS
				U-WASHER	

COMPONENT LIST

A		1 SET	D		1 PC
B	ARM CHAIR (LEFT)	1 SET	E	BACK RAIL	1 PC
C	ARM CHAIR (RIGHT)	1 PC	F	SEAT DECK	1 PC
	FRONT RAIL		G	BACK REST	1 PC
				CUSHION	

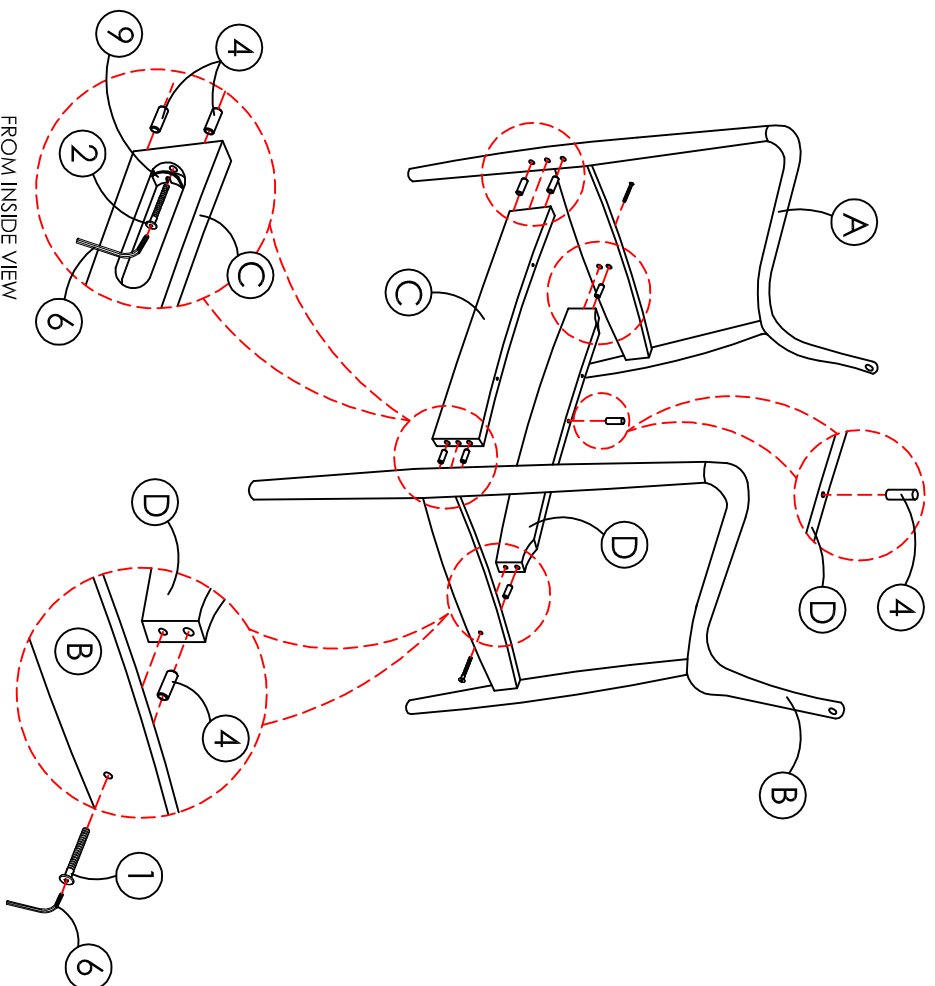

1. Fix arm chair left & right (A & B) to front rail (C) by using WOOD DOWEL (4), JCBC BOLT (2), and U-WASHER (9).
Do not fully tighten.
2. Then fix back rail (D) to arm chair left & right (A & B) by using WOOD DOWEL (4) and JCBC BOLT (2).
3. Insert WOOD DOWEL (4) to the center hole of back rail (D).

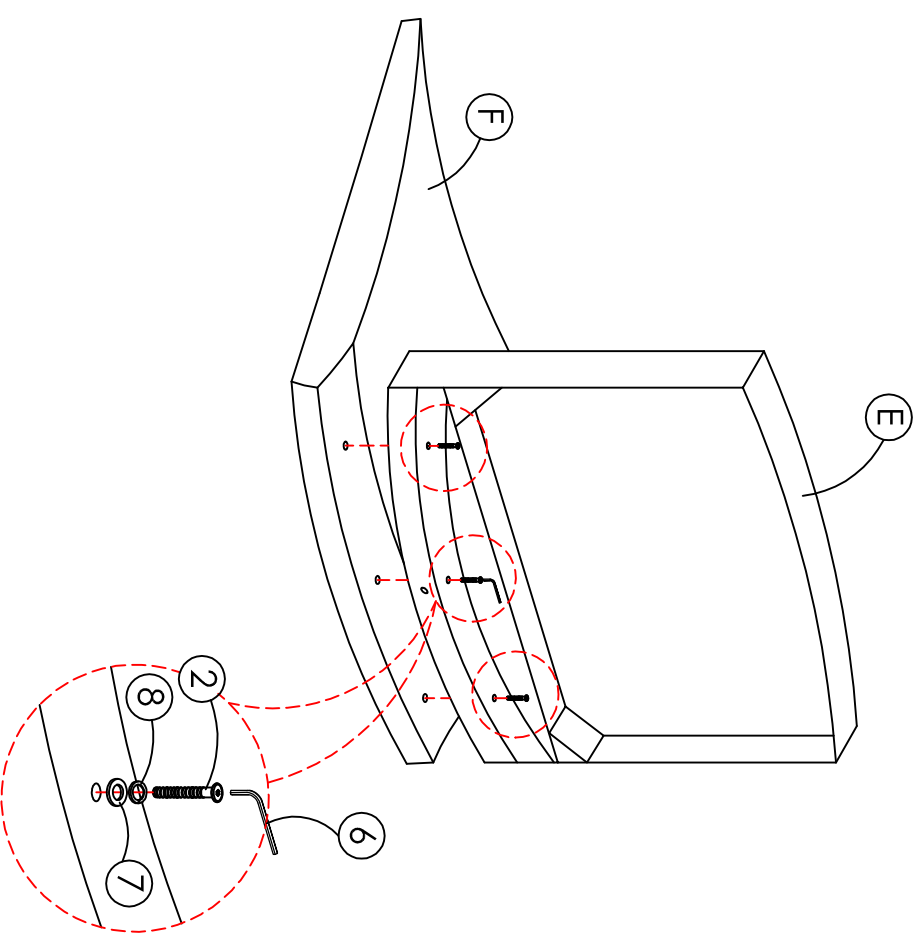

1. Place back rest (F) and seat deck (E) on a platform where the height is parallel with eye view.
2. Remove the black cover underneath of seat deck (E).
2. Fix seat deck (E) to back rest (F) with JCBC BOLT (2), SPRING WASHER (8) and FLAT WASHER (7).
3. Fix the black cover at its original position.

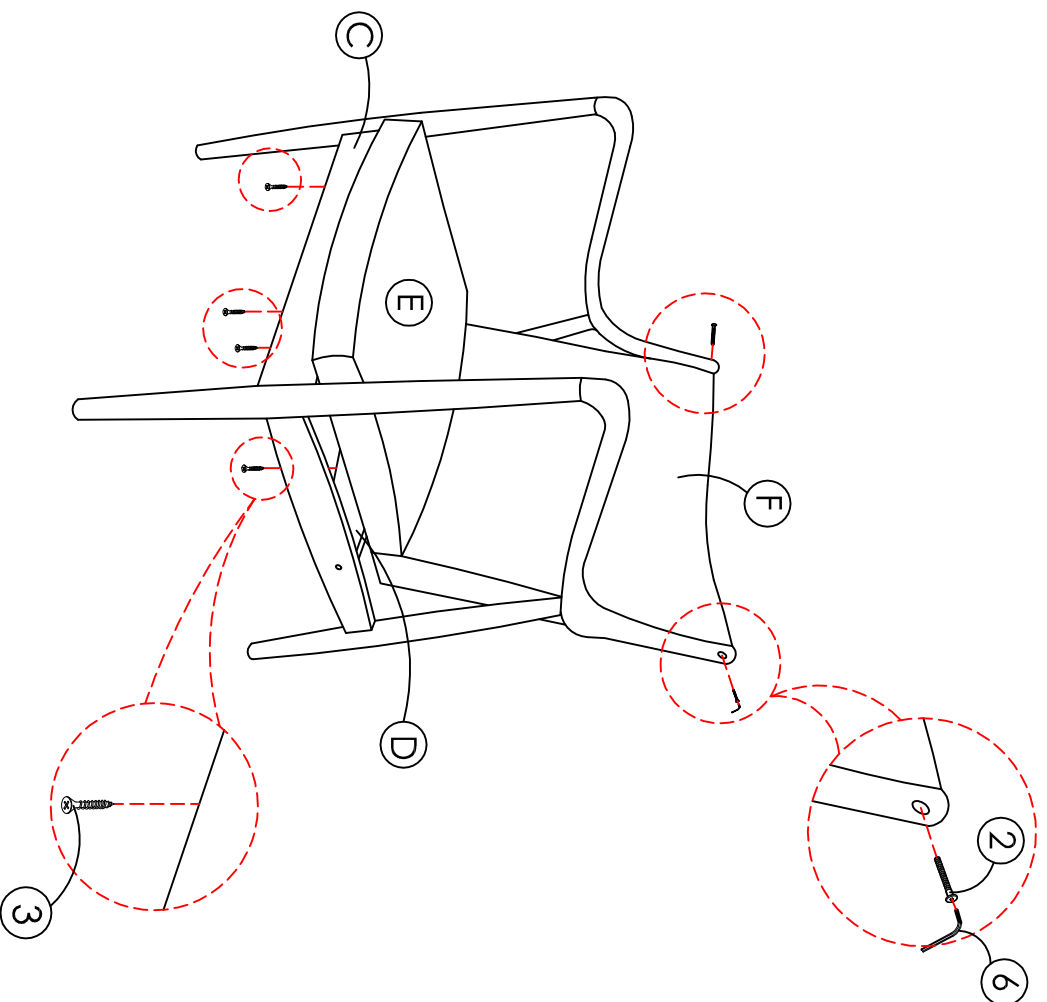

1. Place the seat deck (E) above front rail (C) and back rail (D).
2. Locate the position of wood dowel on center rail (E) and make sure the wood dowel fit into the hole underneath of seat deck (E).
3. Tighten back rest (F) with JCBC BOLT (1) by using ALLEN KEY (6).
4. Then, tighten all other JCBC BOLTS.
5. After that, screw from the bottom of front rail (C) and back rail (D) to seat deck (E) with WOOD SCREW (3).

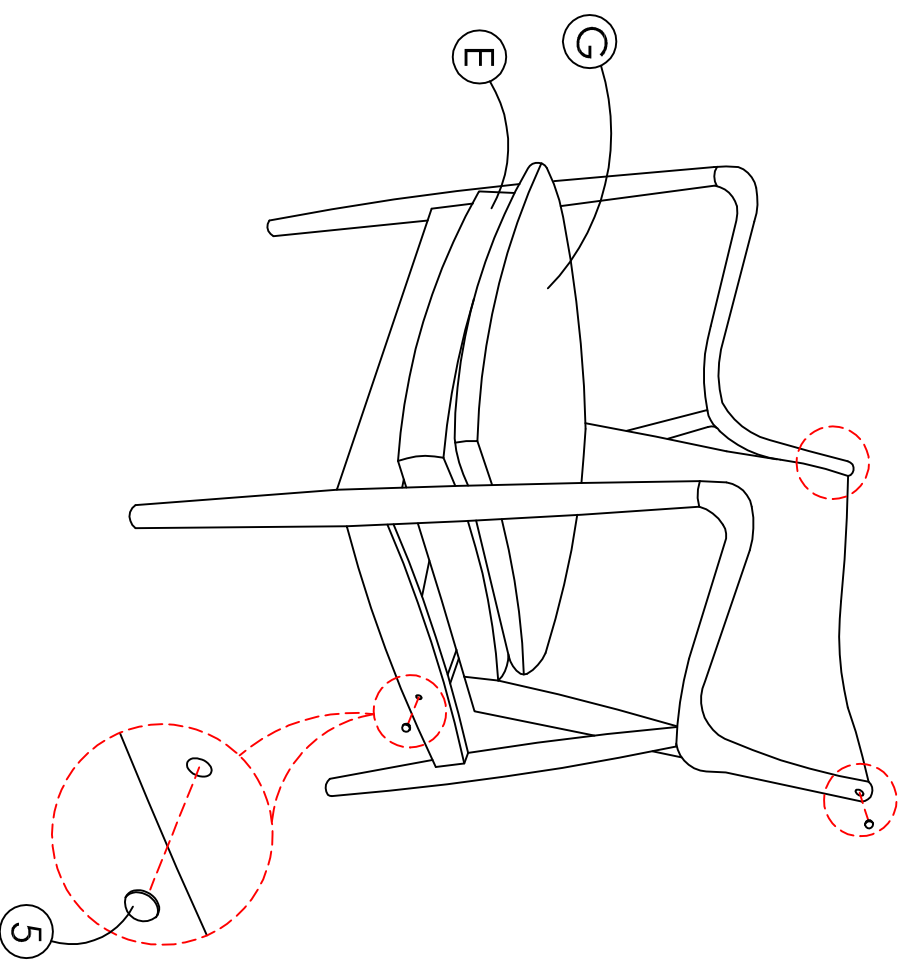

1. Cover the JCBC BOLTS holes with WOODEN CAP (5).
2. Place the cushion (G) above seat deck (E).