

**MODEL NAME:**

**ET 4915-00**

**2.0hr**

**APPROXIMATE ASSEMBLY TIME**

**2 PEOPLE FOR ASSEMBLY**

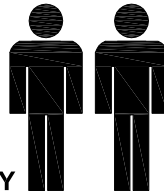

**FLOOR AREA**  
2.0M X 2.0M

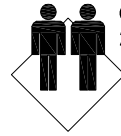

**CEILING HEIGHT**  
2.2M

**REQUIRED ASSEMBLY SPACE**

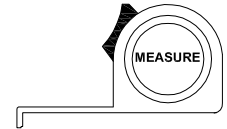
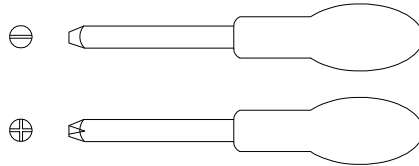
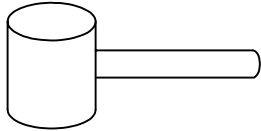

**REQUIRED ASSEMBLY TOOLS**

**ASSEMBLED DIMENSIONS**

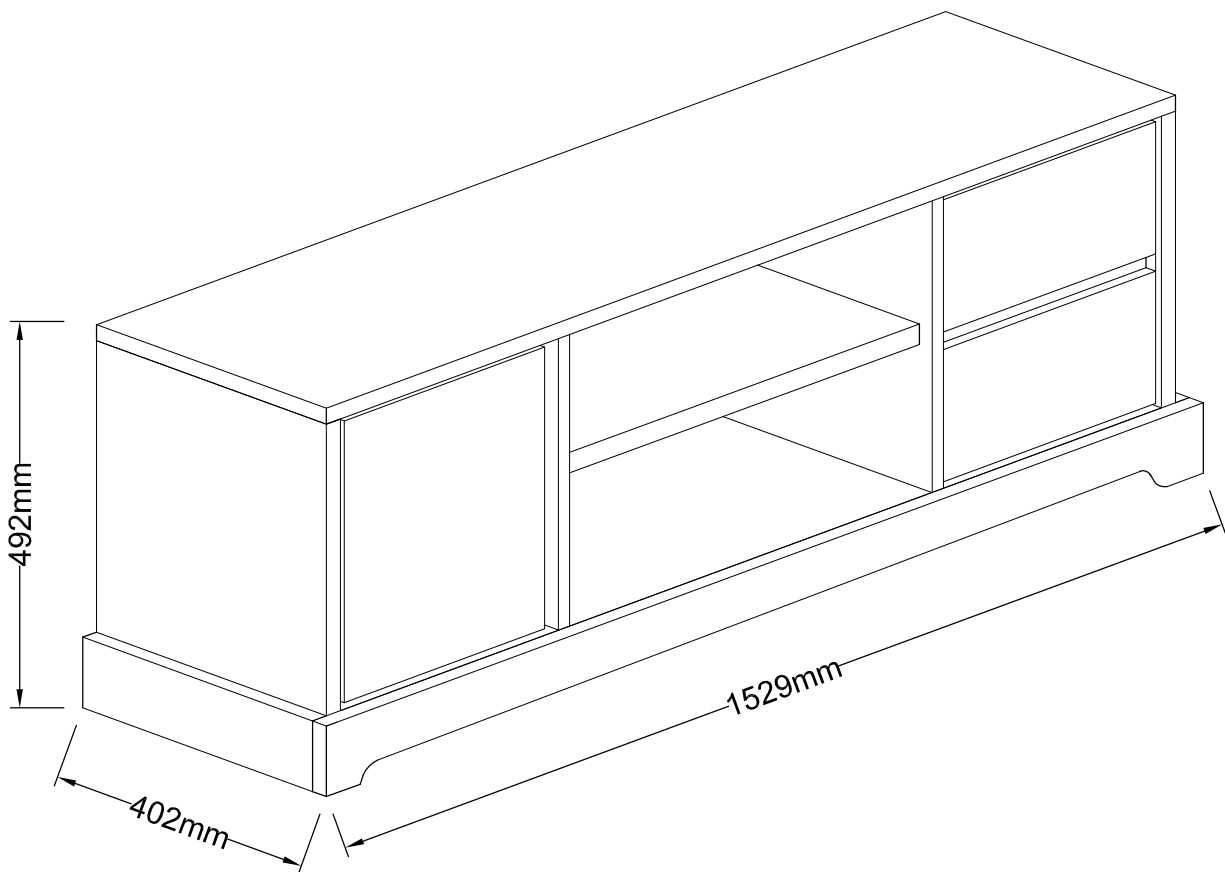

**NOTE : THE MAXIMUM WEIGHT THIS PRODUCT CAN HOLD UP TO IS 25 KGS.**

**MODEL NAME:**

**ET 4915-00**

NO.	PART LIST	QTY	NO.	PART LIST	QTY
(A)	RIGHT SIDE PANEL	1	(P)	DRAWER FRONT	2
(B)	LEFT SIDE PANEL	1	(Q)	DRAWER SIDE (RIGHT)	2
(C)	CENTRE PANEL RIGHT	1	(R)	DRAWER SIDE (LEFT)	2
(D)	CENTRE PANEL LEFT	1	(S)	DRAWER BACK PANEL	2
(E)	TOP PANEL	1	(T)	DRAWER BASE	2
(F)	BOTTOM PANEL	1			
(G)	FIXED SHELF	1			
(H)	BACK SUPPORT	1			
(I)	CENTRE PROFILE	1			
(J)	DOOR PANEL	1			
(K)	DOOR SUPPORT PROFILE	1			
(L)	SIDE PANEL RIGHT	1			
(M)	SIDE PANEL LEFT	1			
(N)	FRONT PANEL	1			
(O)	BOTTOM SUPPORT	1			

**PARTS LIST**

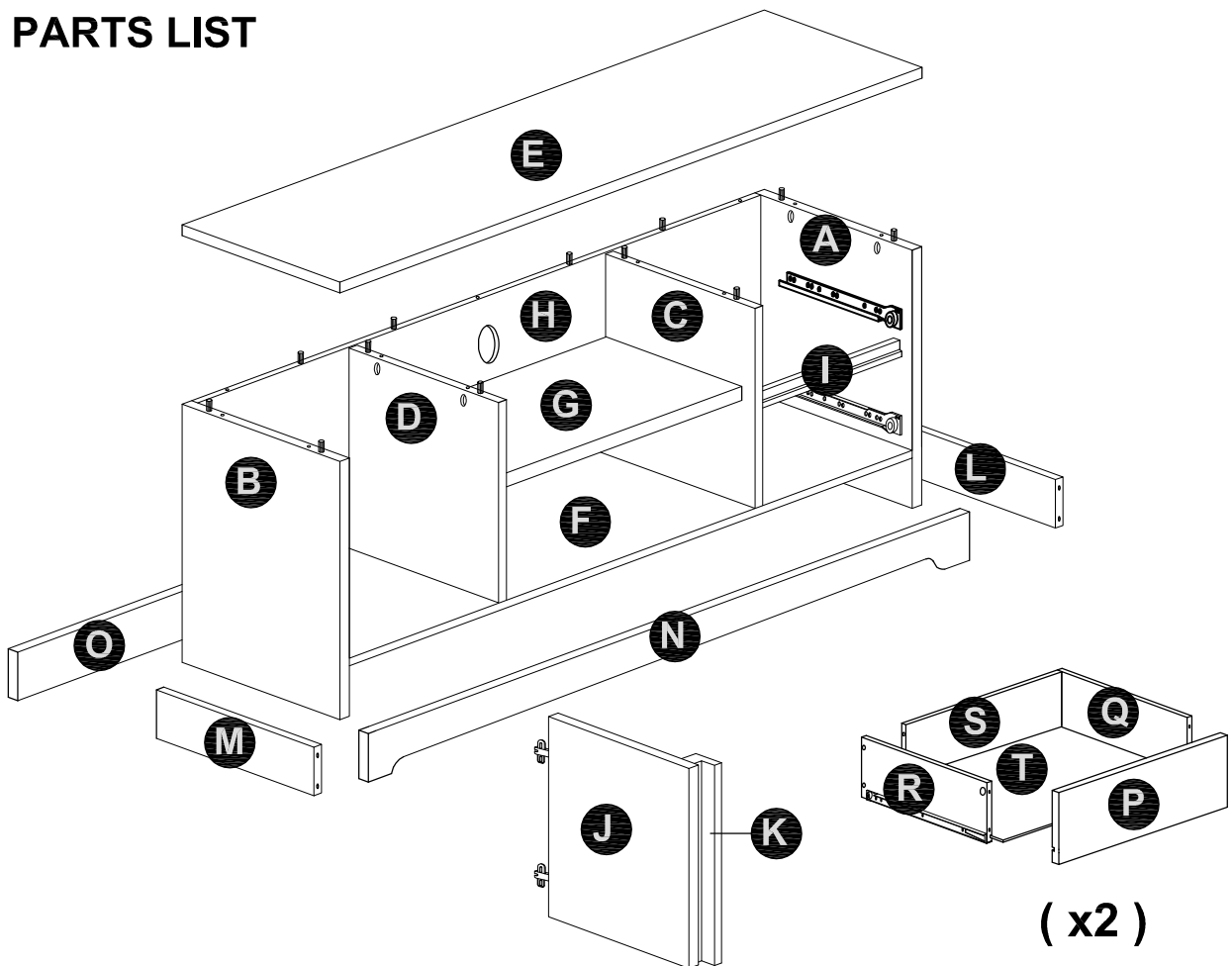







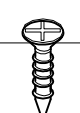
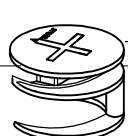
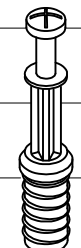
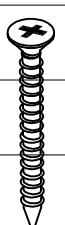
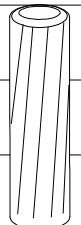
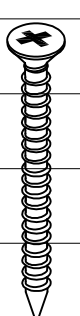
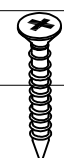

**MODEL NAME:**

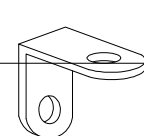
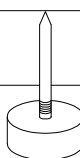
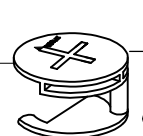
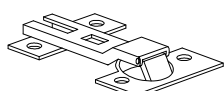
**ET 4915-00**

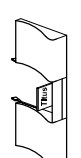
**HARDWARE LIST**

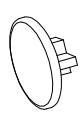
4cm  
3cm  
2cm  
1cm  
0cm

 <b>7X</b> M3.5 x 12mm <b>1</b> FLAT HEAD SCREW	 <b>19X</b> Dia.15mm <b>2</b> LARGE CAM-LOCK	 <b>26X</b> M6.5 <b>3</b> CAM BOLT	 <b>11X</b> M3.5 x 25mm <b>4</b> FLAT HEAD SCREW	 <b>48X</b> Dia.6 x 30mm <b>5</b> WOOD DOWEL	
 <b>10X</b> M8 x 38mm <b>6</b> FLAT HEAD SCREW	 <b>8X</b> M8 x 5/8mm <b>7</b> FLAT HEAD SCREW	 <b>1X</b> Dia 8mm <b>8</b> DOOR STOPPER	 <b>3X</b> <b>9</b> METAL L-BRACKET	 <b>9X</b> <b>10</b> FOOT	 <b>7X</b> Dia.15mm <b>11</b> SMALL CAM-LOCK
 <b>2X</b> <b>12</b> ADJUSTABLE HINGE	 <b>2X</b> <b>13</b> GLUE 10CC	 <b>1X</b> <b>14</b> DOOR SOFT CLOSE	 <b>6X</b> M4 x 30mm <b>15</b> FLAT HEAD SCREW	 <b>3X</b> Dia 17mm <b>16</b> UNIVERSAL CAP (OPTIONAL)	 <b>3X</b> Dia.13mm <b>17</b> SCREW COVER (OPTIONAL)

## **MODEL NAME:**

# **ET 4915-00**

### **Top Tips before you start!**

1. Please check that all parts are present before you start the assembly of your furniture.
2. For ease and speed of assembly, we recommend that before you commence each step of the assembly, that you identify all the parts required for that step.
3. For larger items, please ensure that you have sufficient space and people ( as indicated on page 1 ) to assemble your product safely
4. We recommend that, where possible, all items are assembled near to the area in which they will be placed in use, to avoid moving the product unnecessarily once assembled.
5. For the protection of your furniture, particularly items of high gloss finish, we recommend that the product is placed on a protected surface during assembly to prevent any damage.
6. Caution - Electric / Battery operated screw driver NOT RECOMMENDED.
7. During assembly please take care not to over-tighten any fittings, as this may damage the product.
8. Always place the product on a flat, steady and stable surface.
9. Do not sit or stand on the product.  
Do not use the product as a stepladder.
10. This product is intended for indoor, household use only as it is non industrial product.
11. This product is constructed from re-inforced hollow board. Excessive pressure cause irreparable damage. Please do not kneel on any part of this product during assembly.

### **Care and Maintenance of your Furniture**

- Please periodically check all fittings and re-tighten as necessary.
- To clean your item, please use a damp cloth and wipe clean.
- Never allow any kind of liquid to remain on your furniture.
- Please do not place hot items (e.g. hot drinks ) directly on to the wood surface.
- Please do not drag and pull your furniture.

MODEL NAME:

ET 4915-00

# SPECIAL TIPS FOR FITTING CAM-LOCKS AND CAM BOLT

LARGE CAM-LOCK

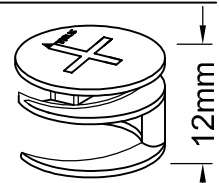

WHEN FITTING CAM-LOCK  
ENSURE STARTING POSITION IS CORRECT  
BEFORE YOU INSERT CONNECTING CAM BOLT  
TURN CLOCKWISE UNTIL SECURE

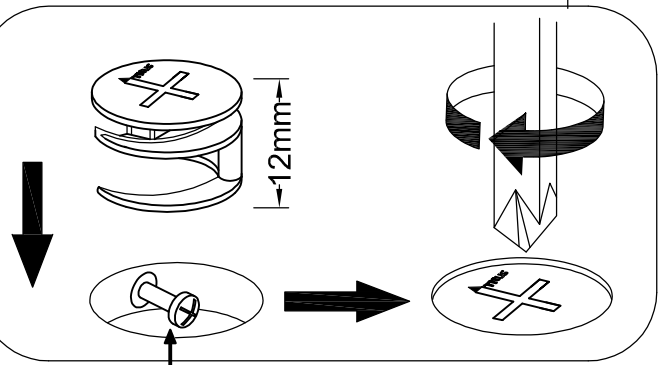
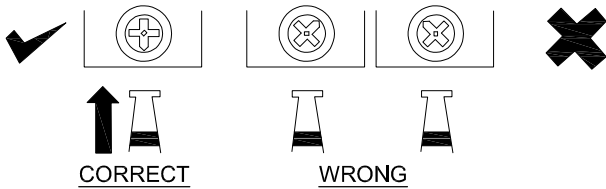

Cam bolt head needs to be in centre

SMALL CAM-LOCK

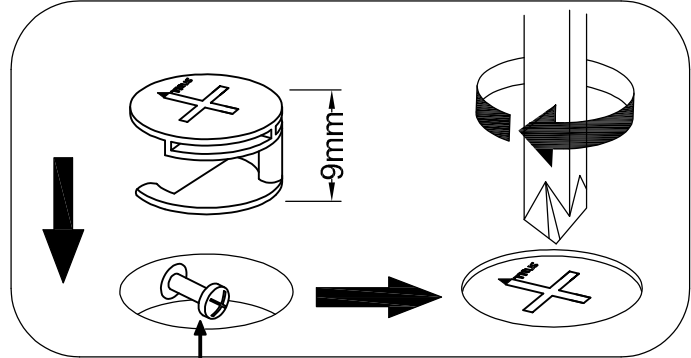
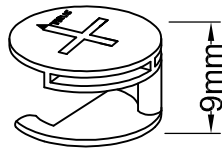

Cam bolt head needs to be in centre

CAM BOLT

Tighten until shoulder is flush with panel. Do not overtighten or undertighten (see example below)

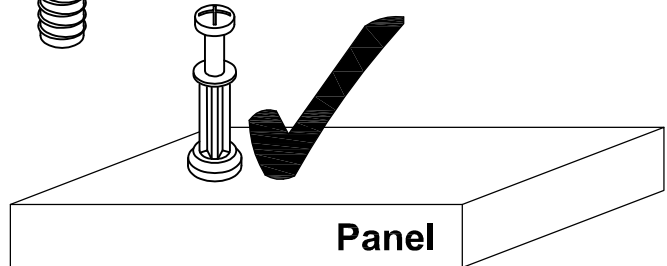
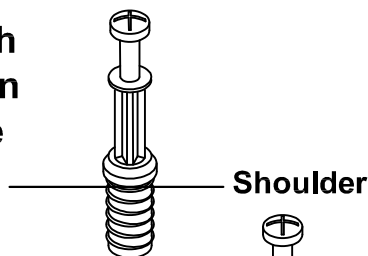
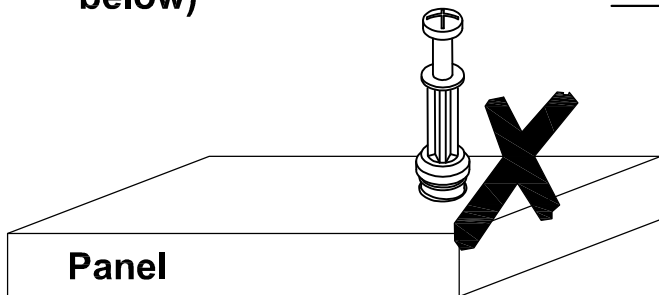

MODEL NAME:

ET 4915-00

**STEP 1**

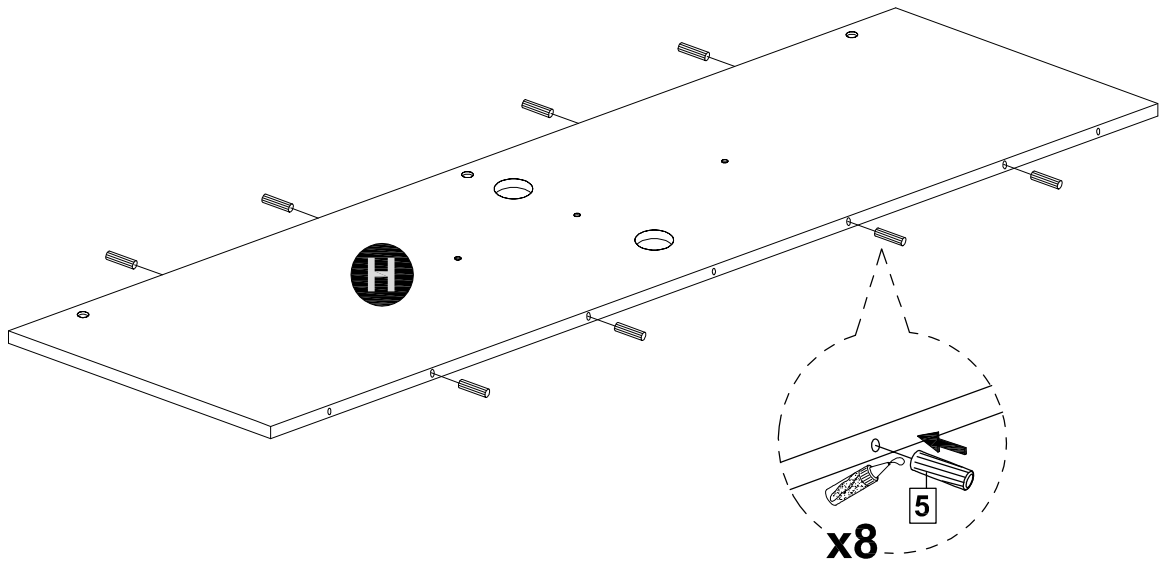

**STEP 2**

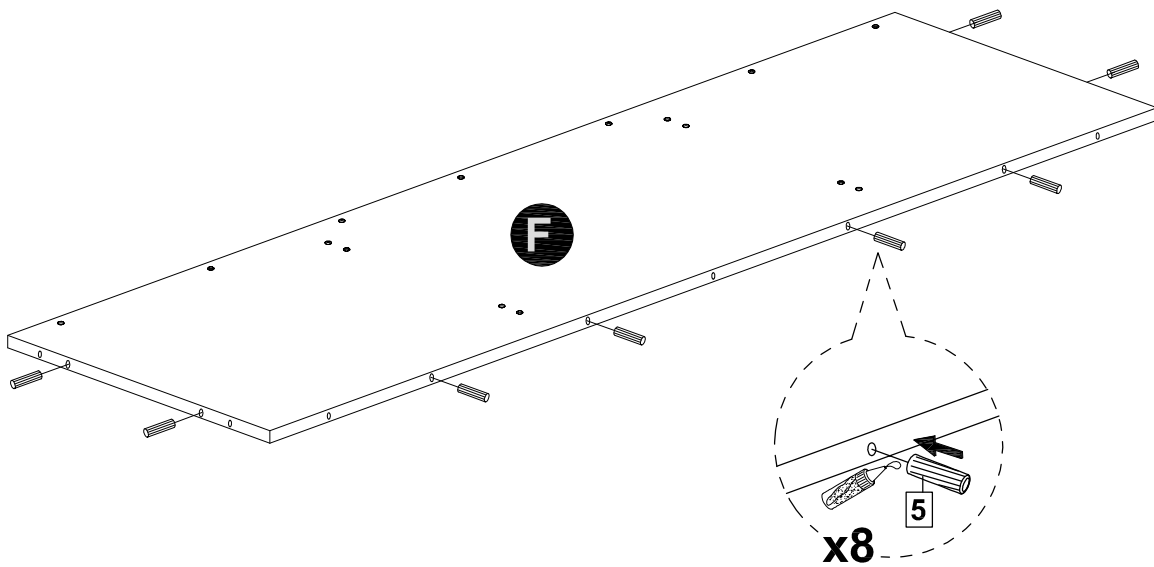

MODEL NAME:

ET 4915-00

**STEP 3**

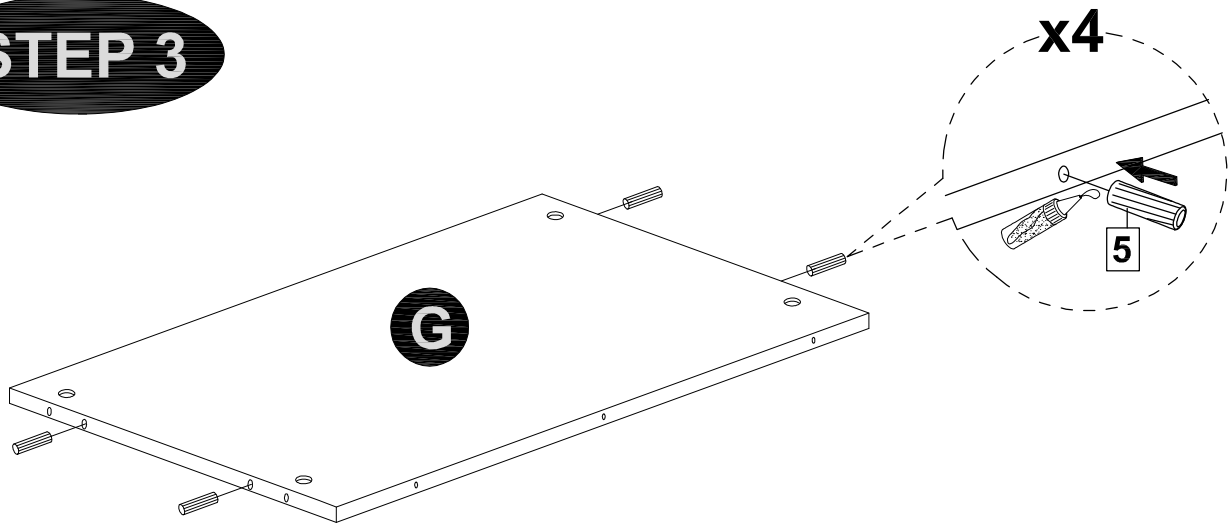

**STEP 4**

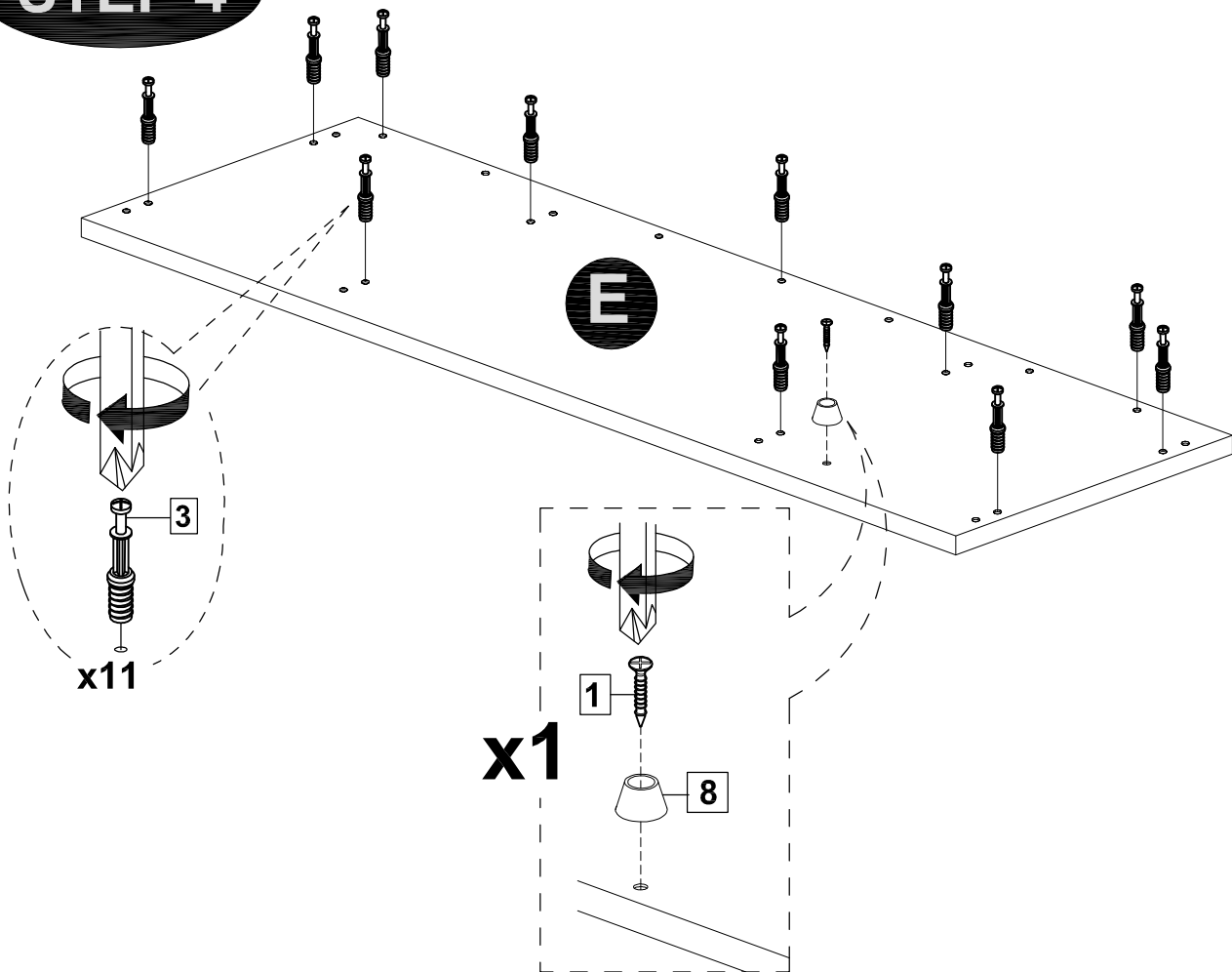

MODEL NAME:

ET 4915-00

**STEP 5**

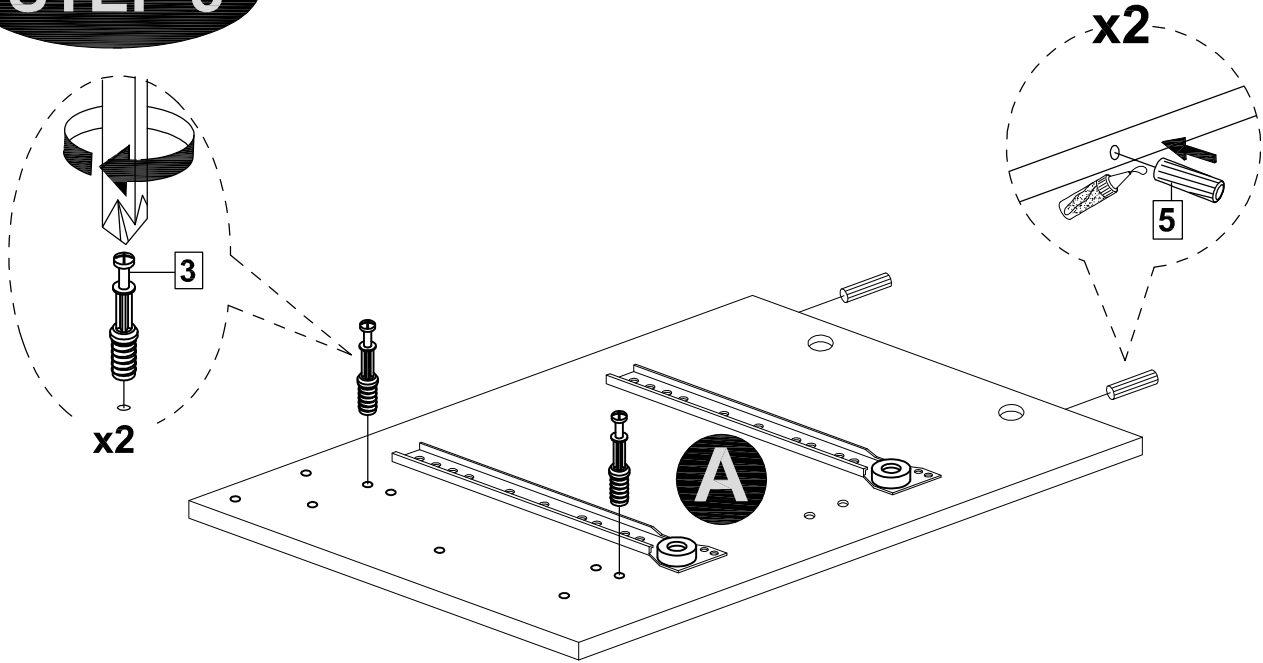

**STEP 6**

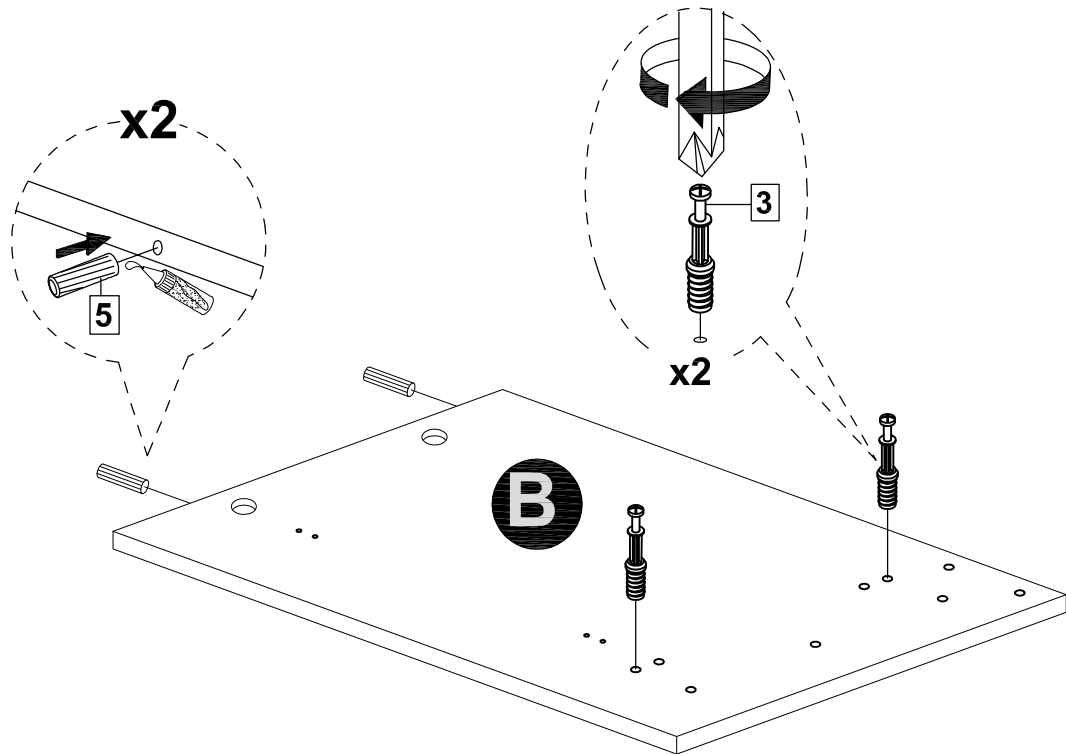



MODEL NAME:

ET 4915-00

**STEP 7**

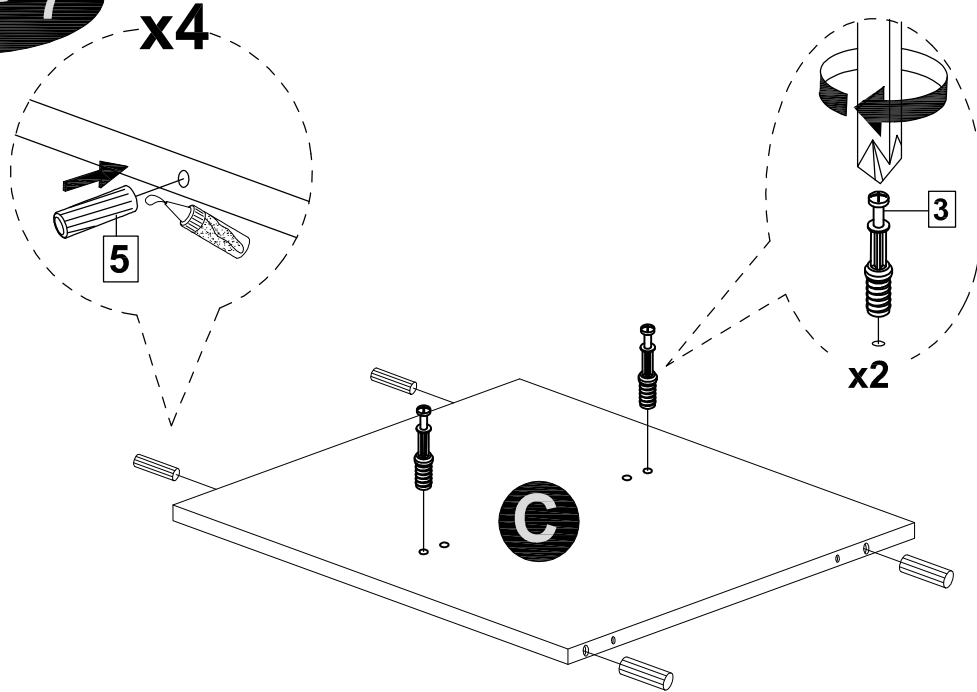

**STEP 8**

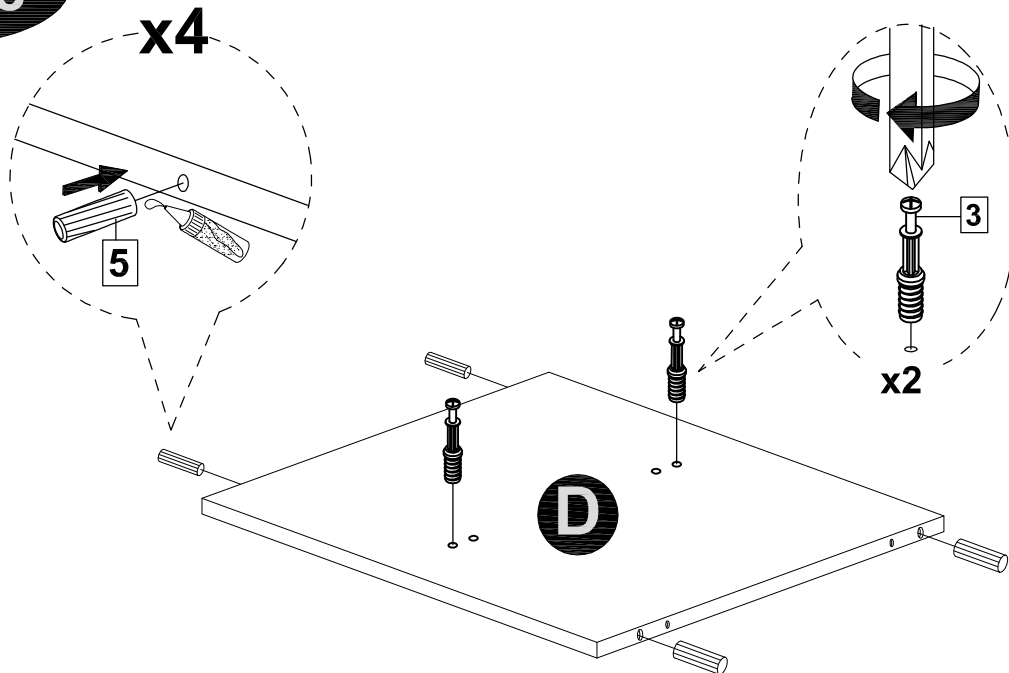

MODEL NAME:

ET 4915-00

**STEP 9**

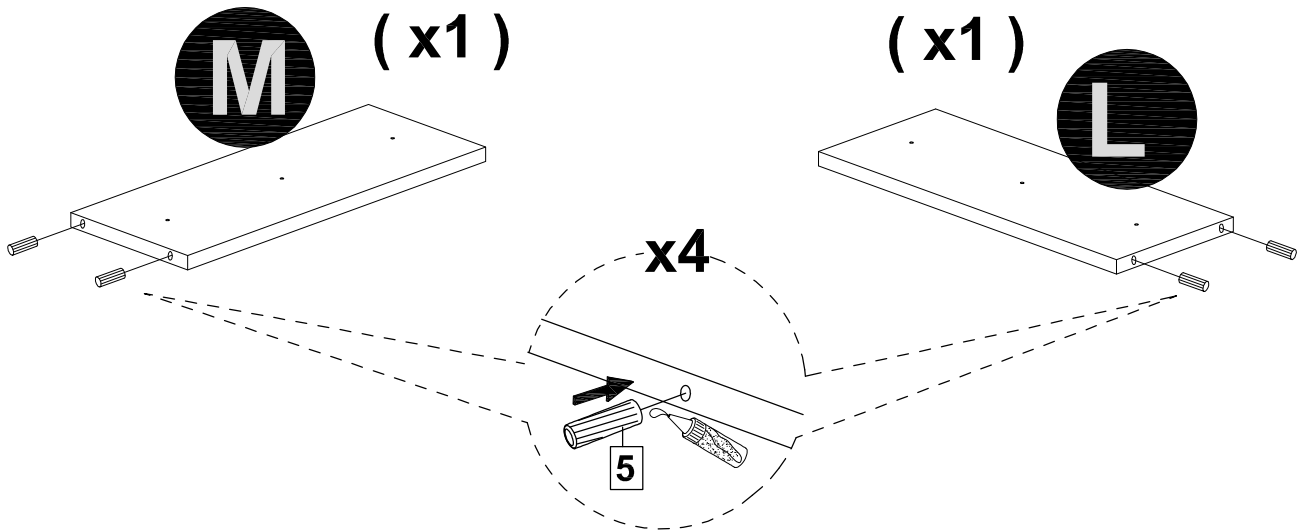

**STEP 10**

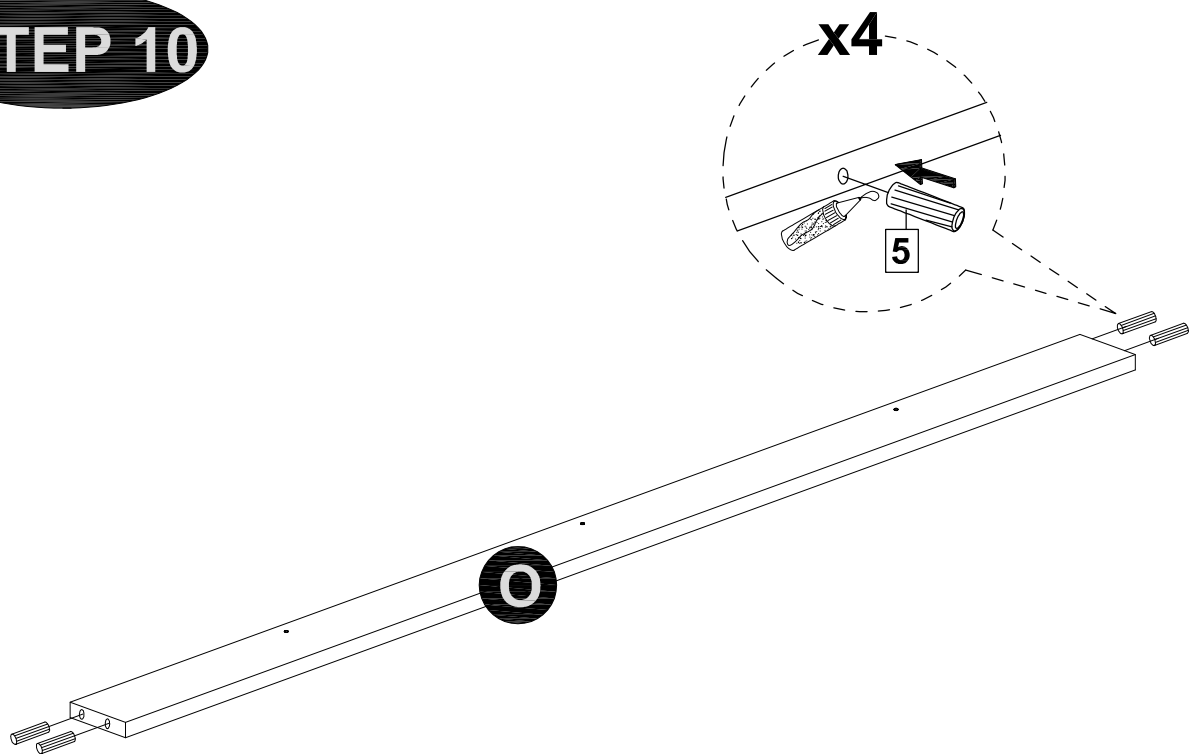

MODEL NAME:

ET 4915-00

**STEP 11**

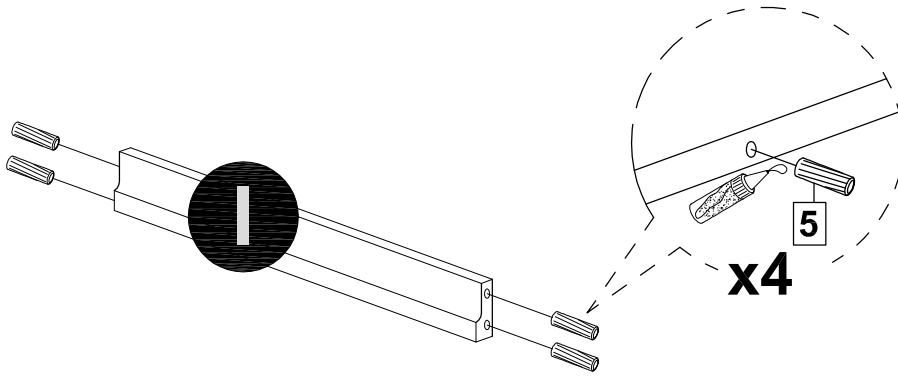

**STEP 12**

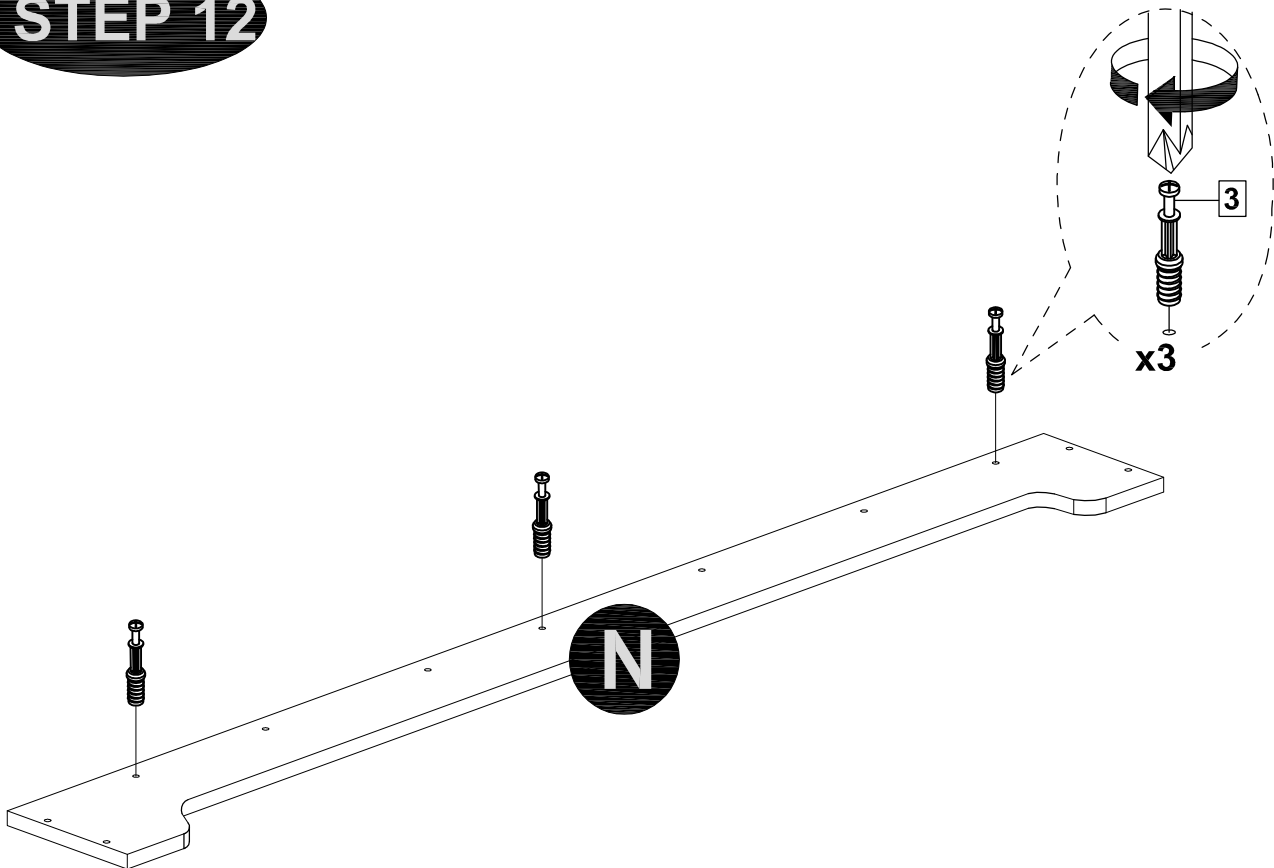

MODEL NAME:

ET 4915-00

**STEP 13**

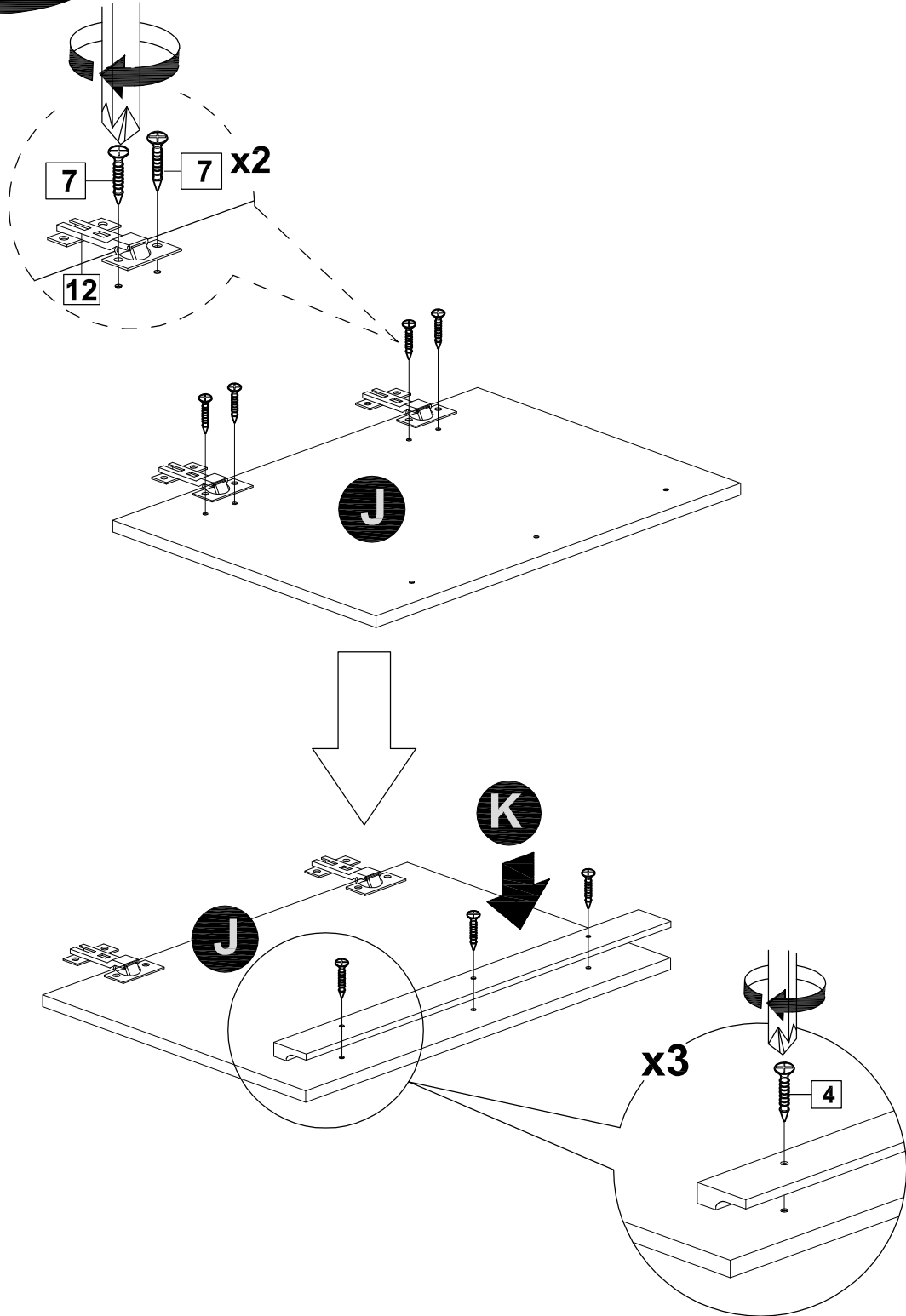

MODEL NAME:

ET 4915-00

**STEP 14**

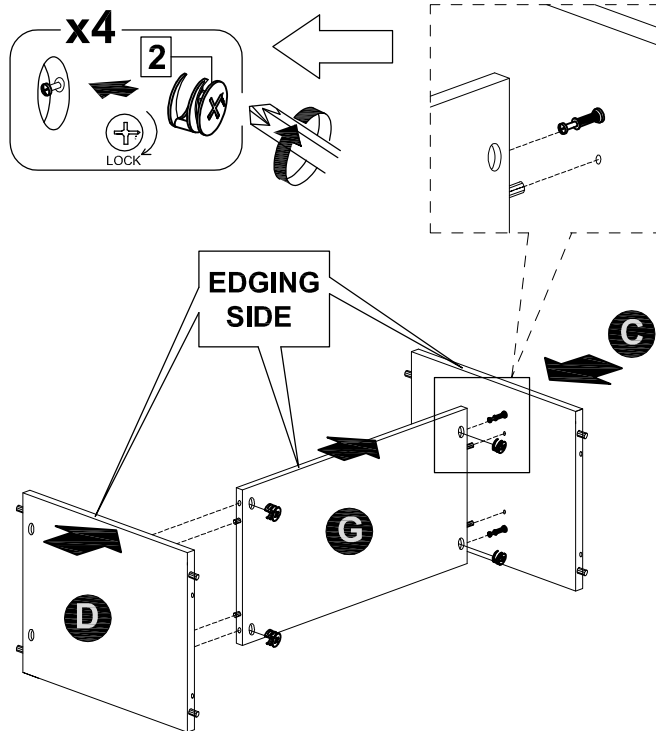
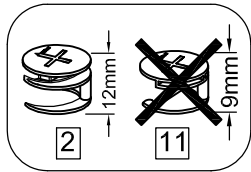

**STEP 15**

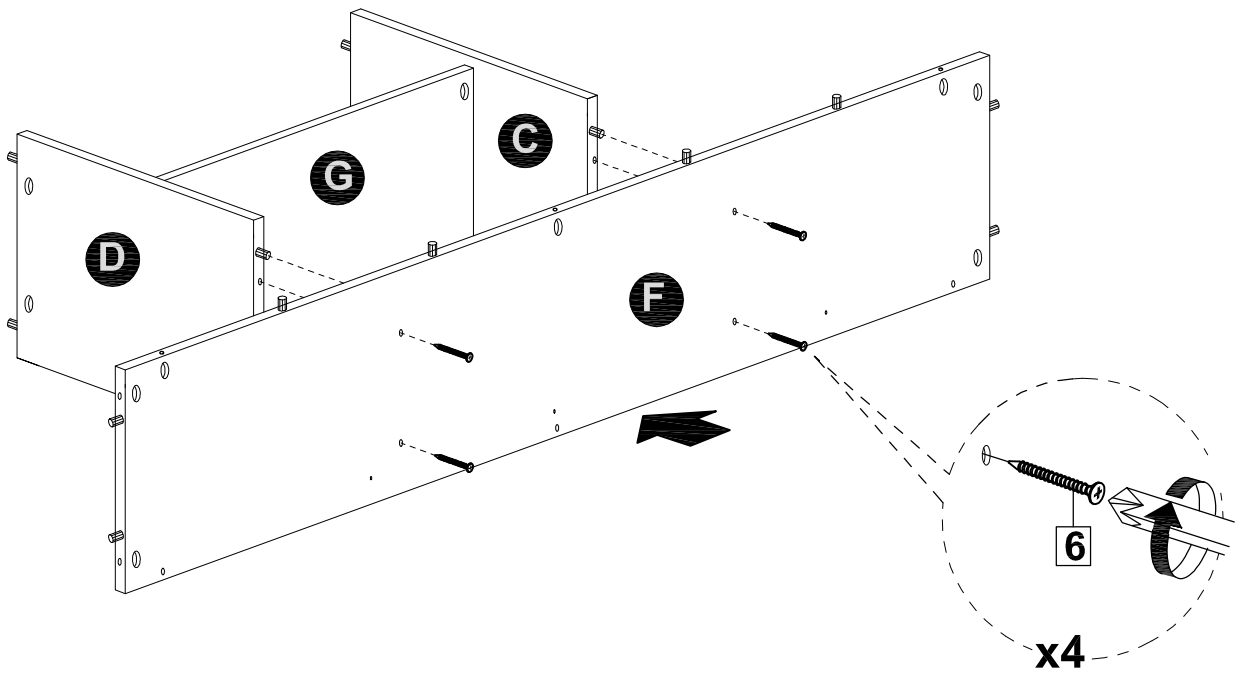

MODEL NAME:

ET 4915-00

**STEP 16**

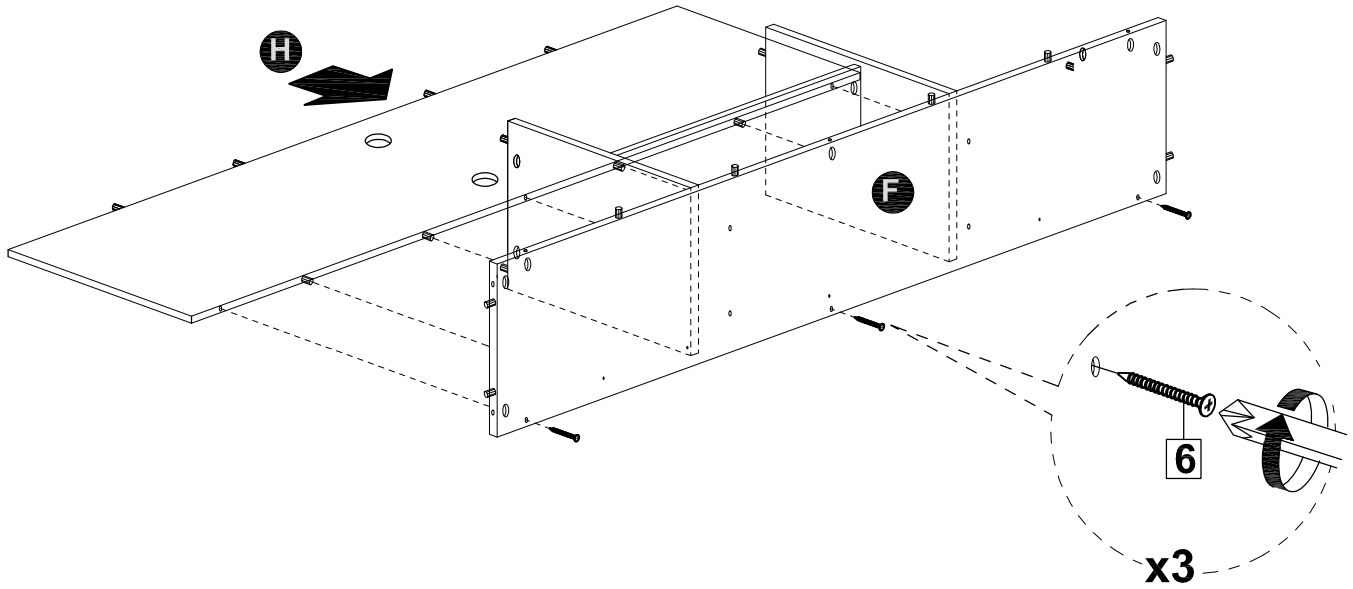

**STEP 17**

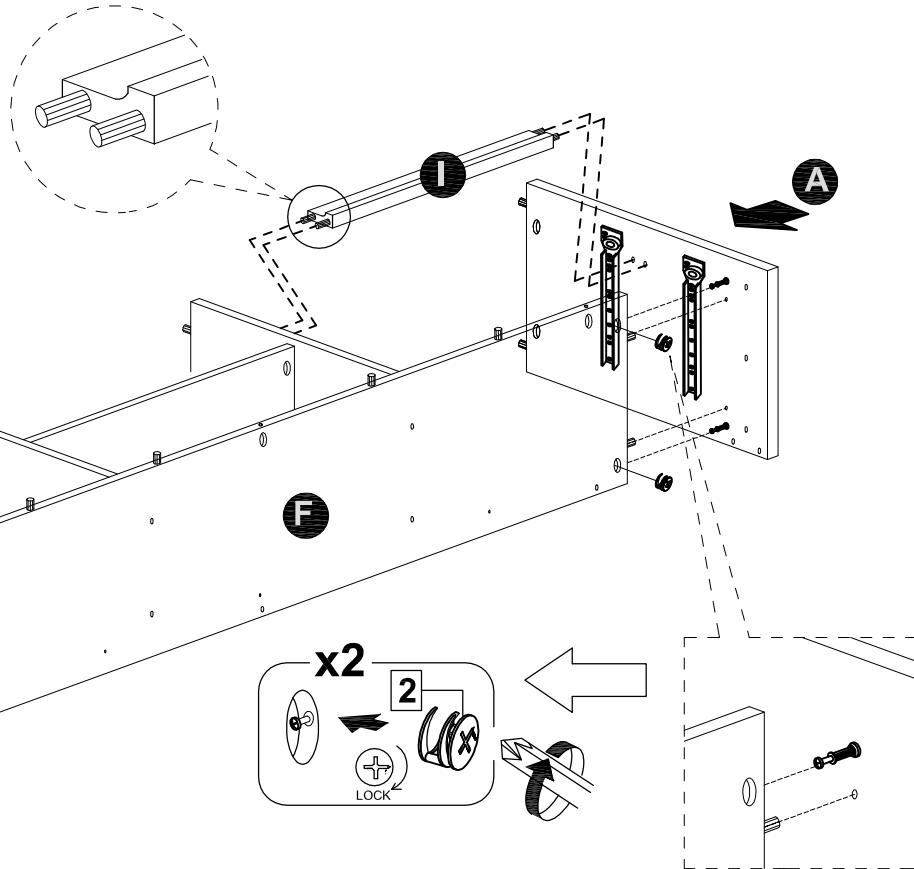
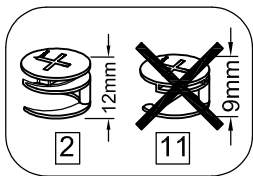

MODEL NAME:

ET 4915-00

**STEP 18**

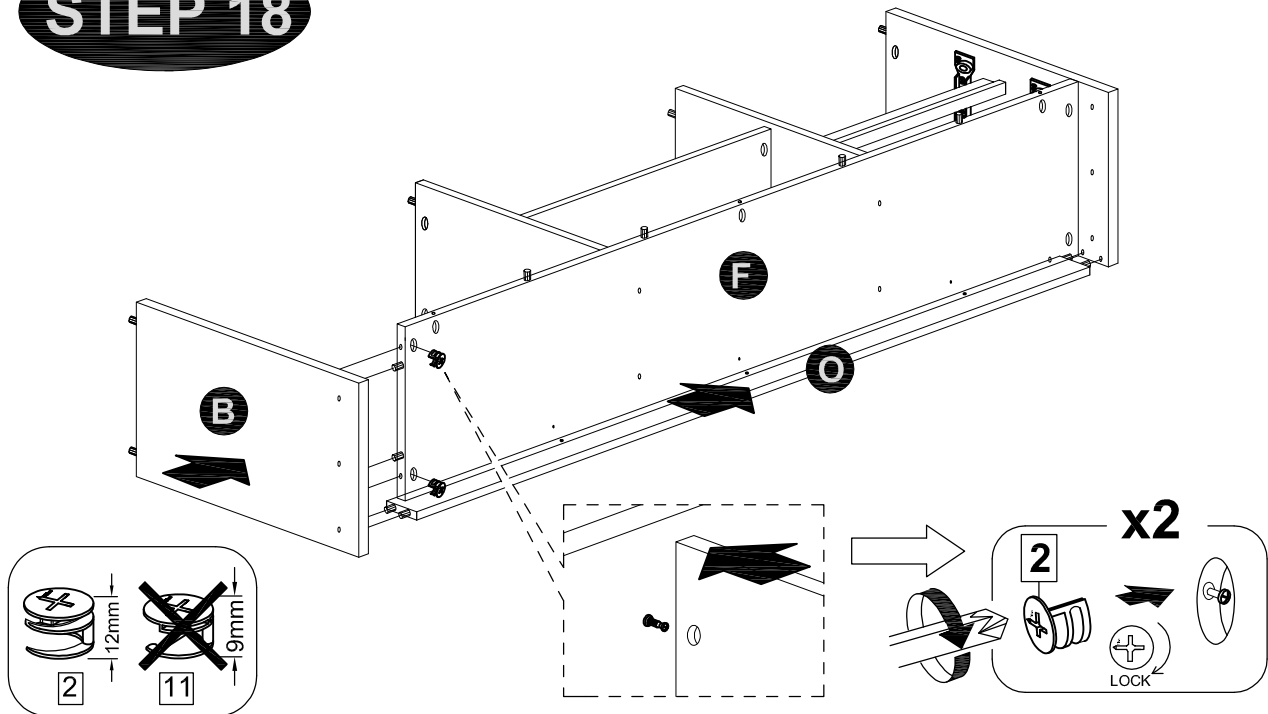

**STEP 19**

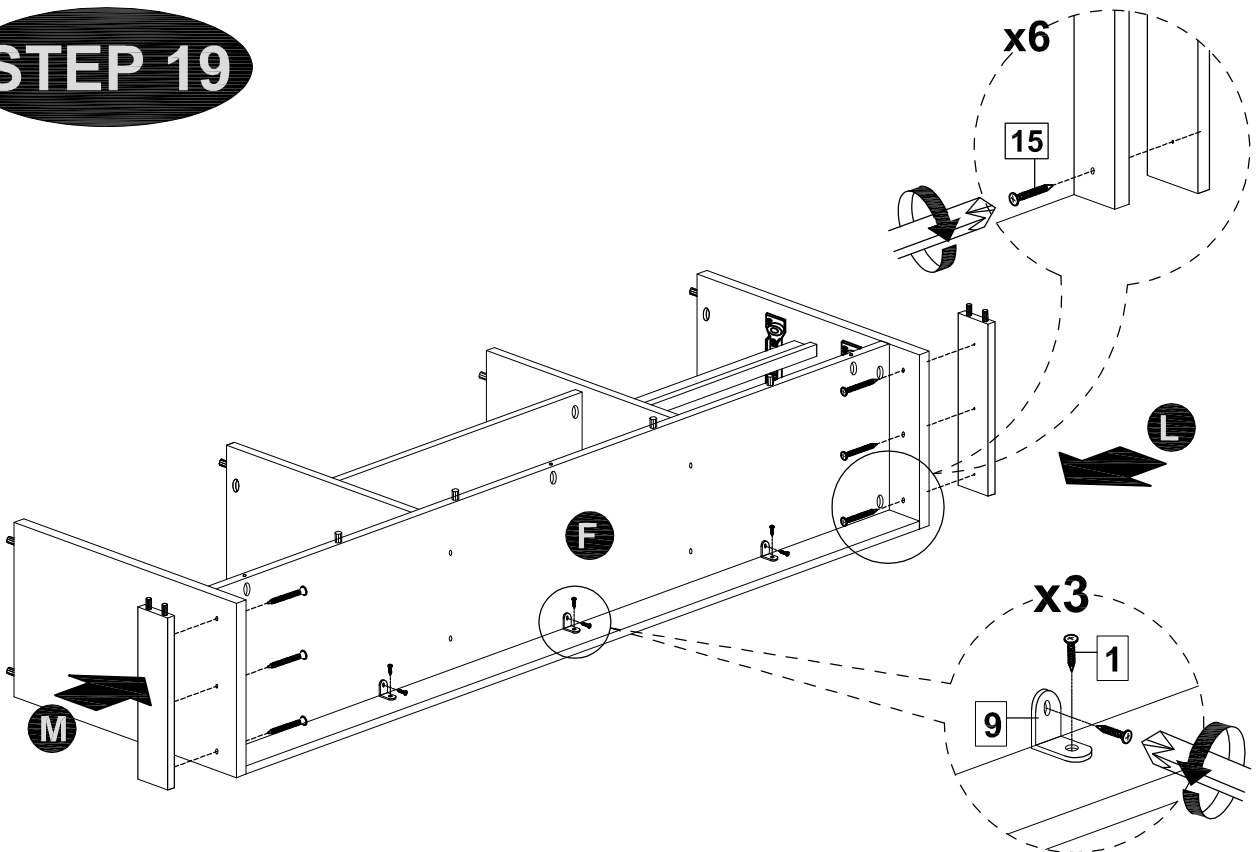

MODEL NAME:

ET 4915-00

**STEP 20**

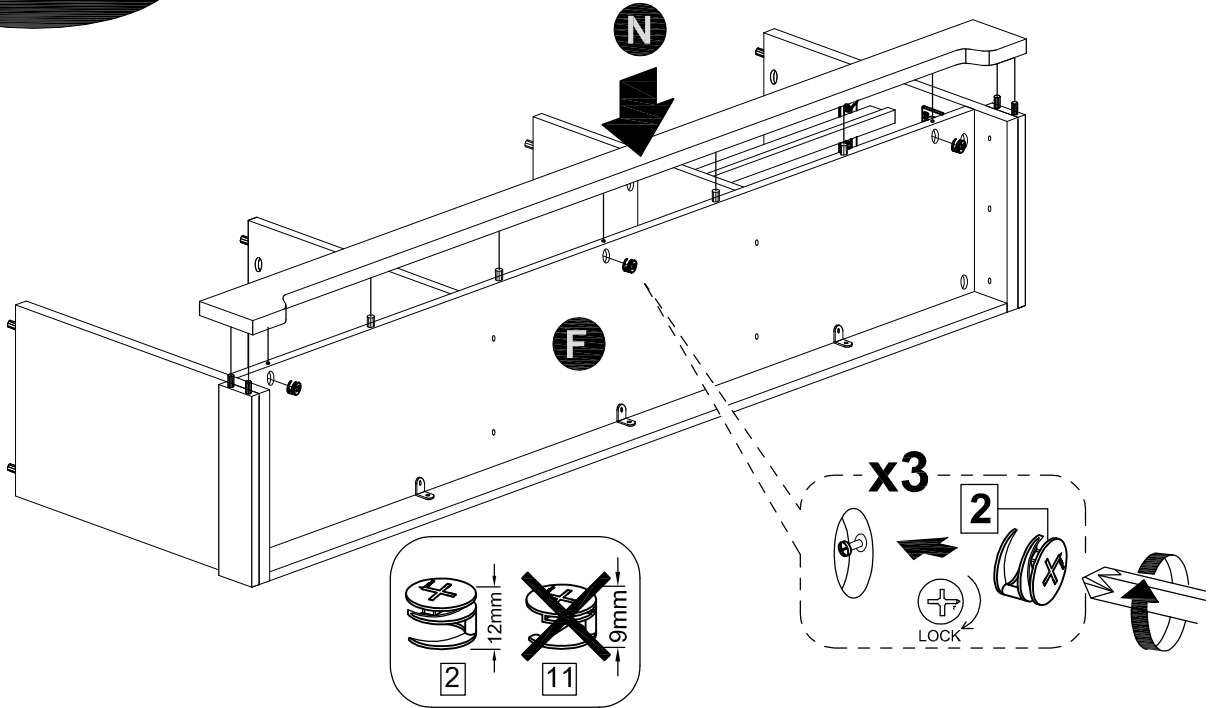

**STEP 21**

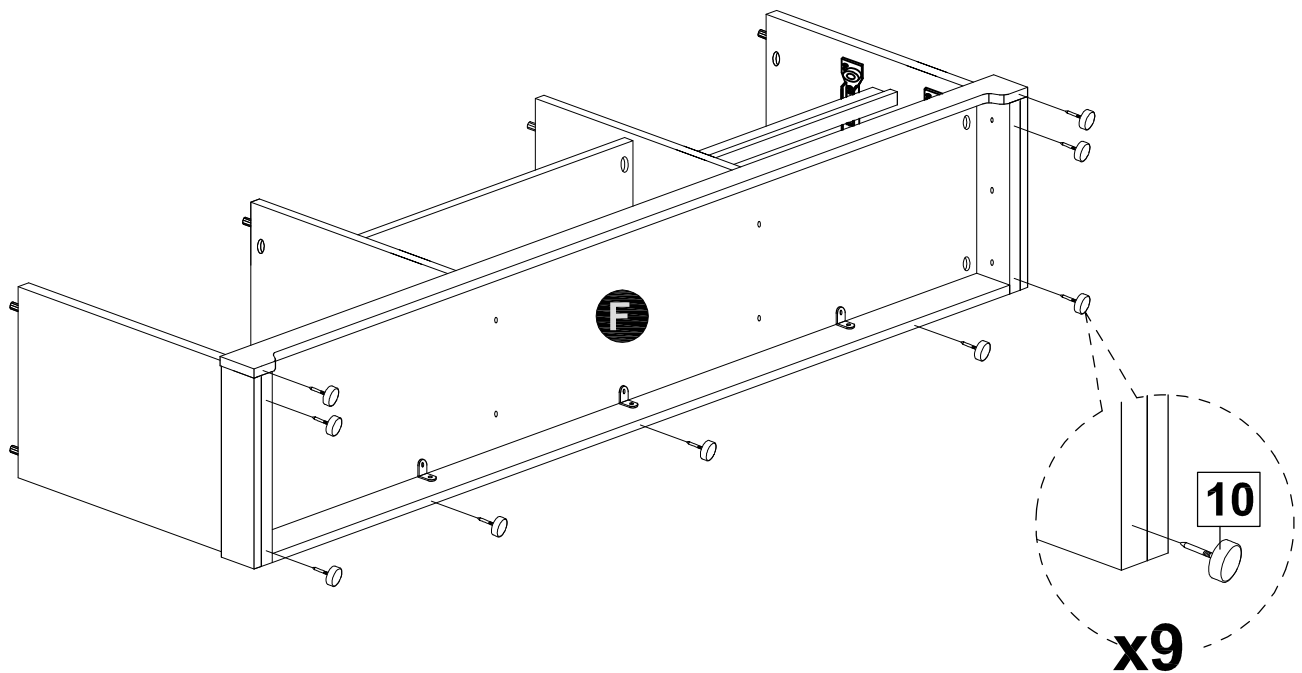



MODEL NAME:

ET 4915-00

**STEP 22**

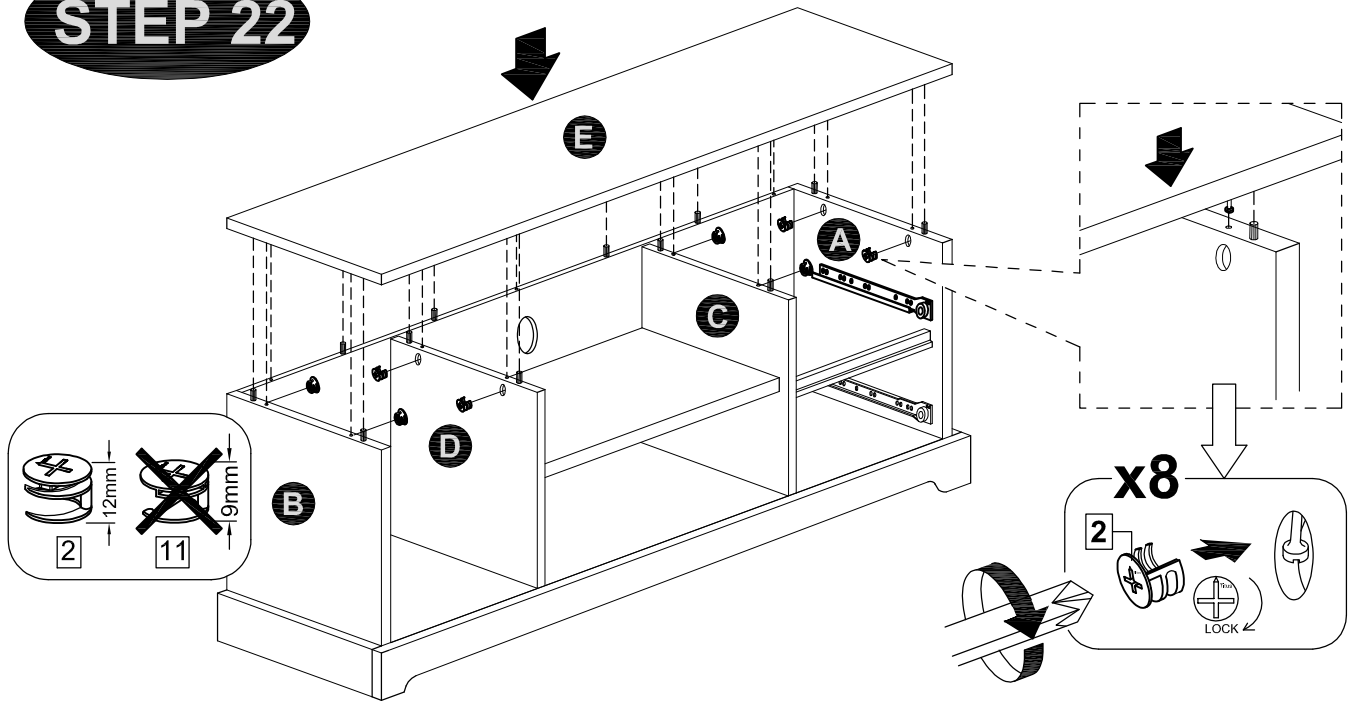

**STEP 23**

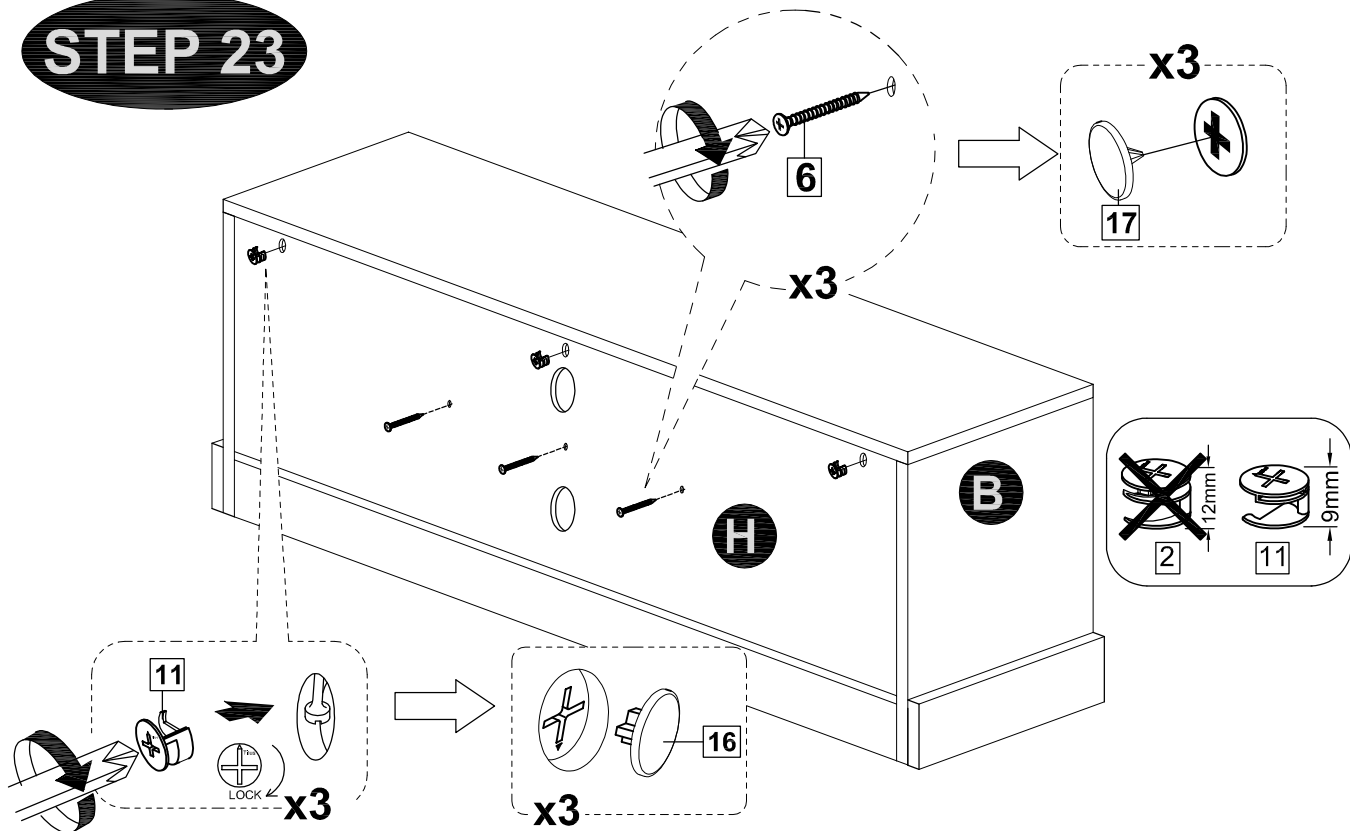

MODEL NAME:

ET 4915-00

**STEP 24**

**Hinge Adjustment**

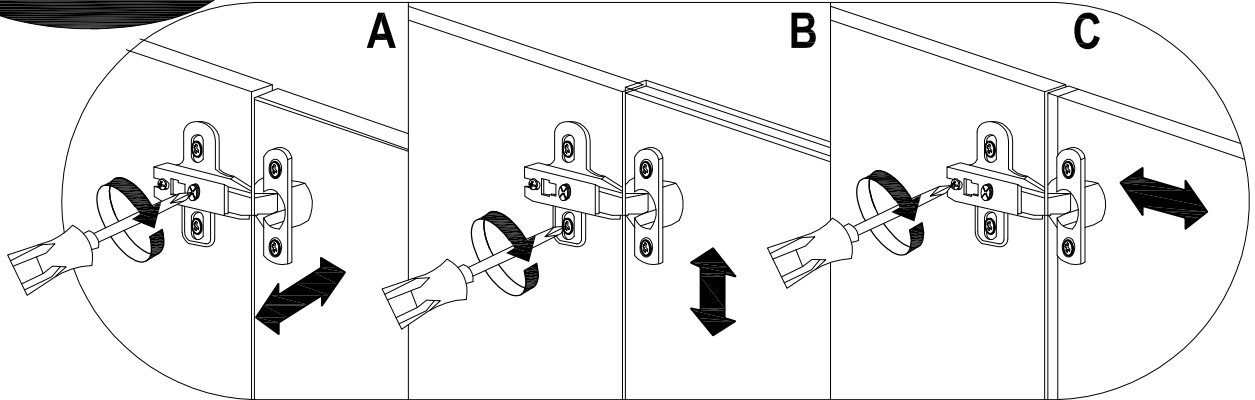

**A. Lateral adjustment by screw adjusting**

**B. Vertical adjustment via slot in the mounting plate**

**C. Front-to-Back by slacking the hinge arm mounting screw**

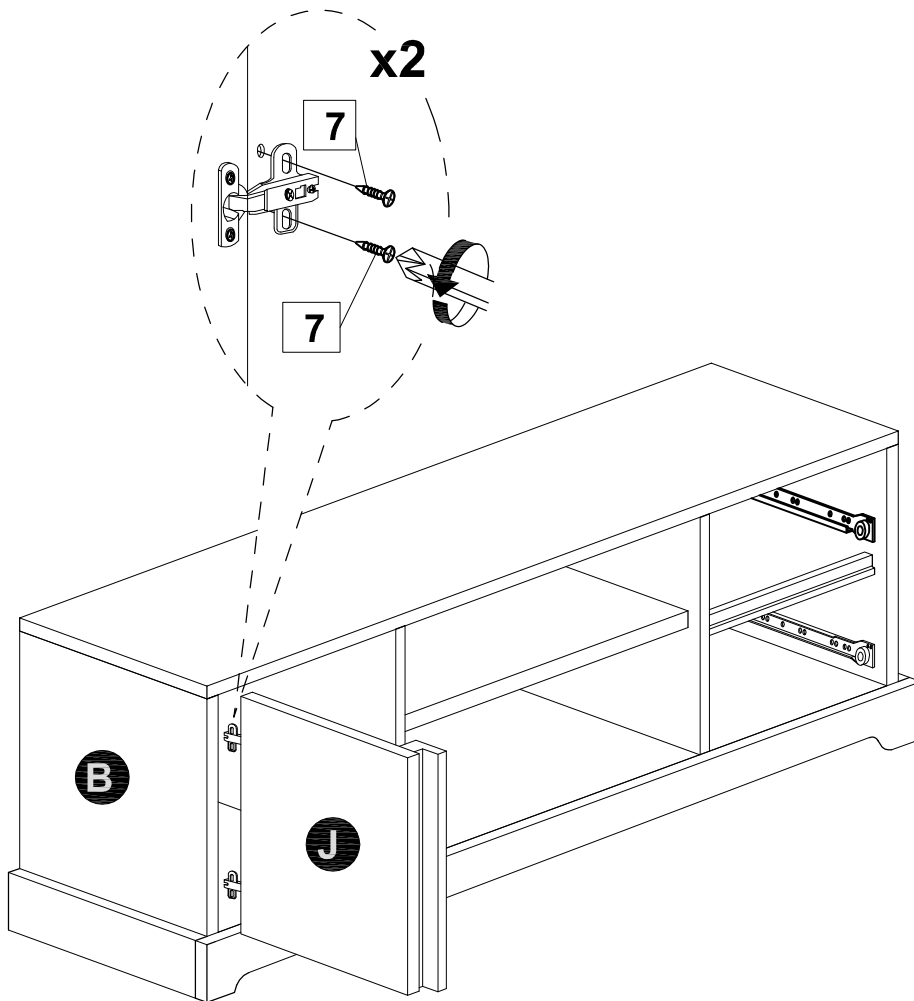

MODEL NAME:

ET 4915-00

**STEP 25**

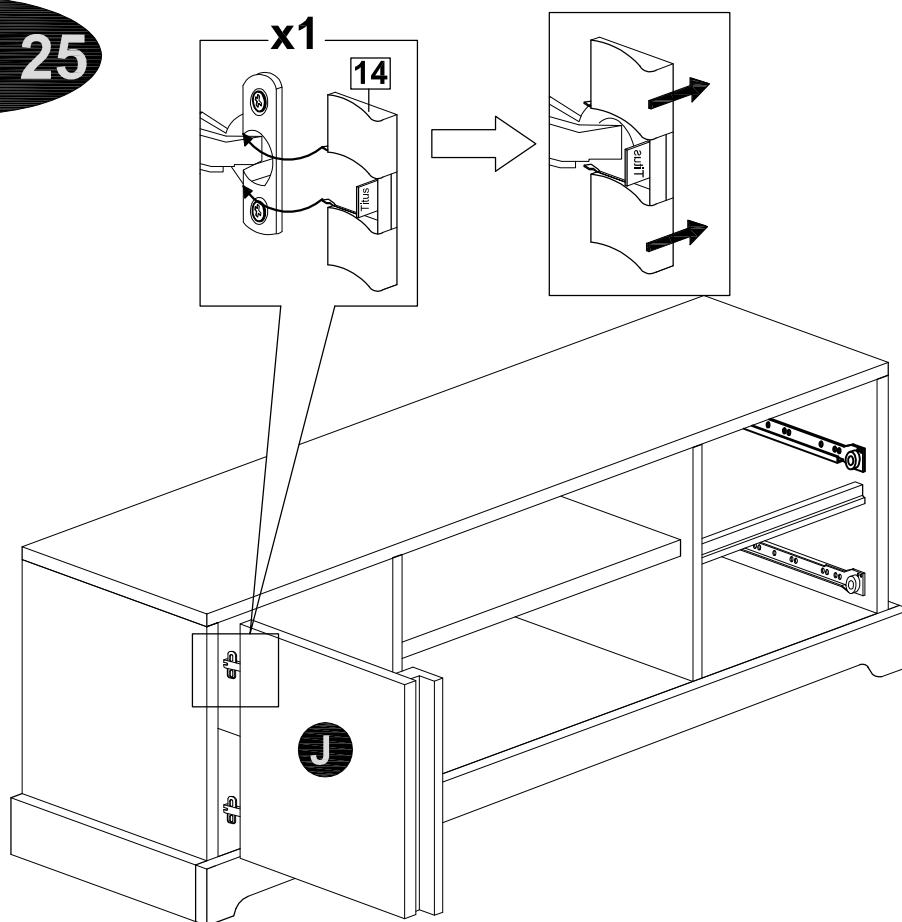

**STEP 26**

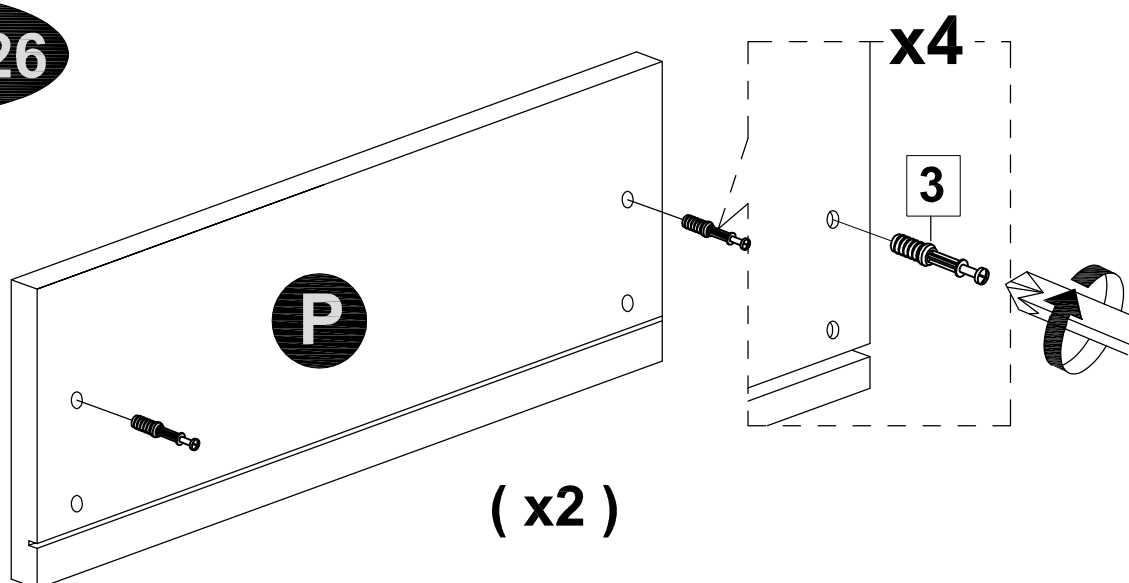

MODEL NAME:

ET 4915-00

**STEP 27**

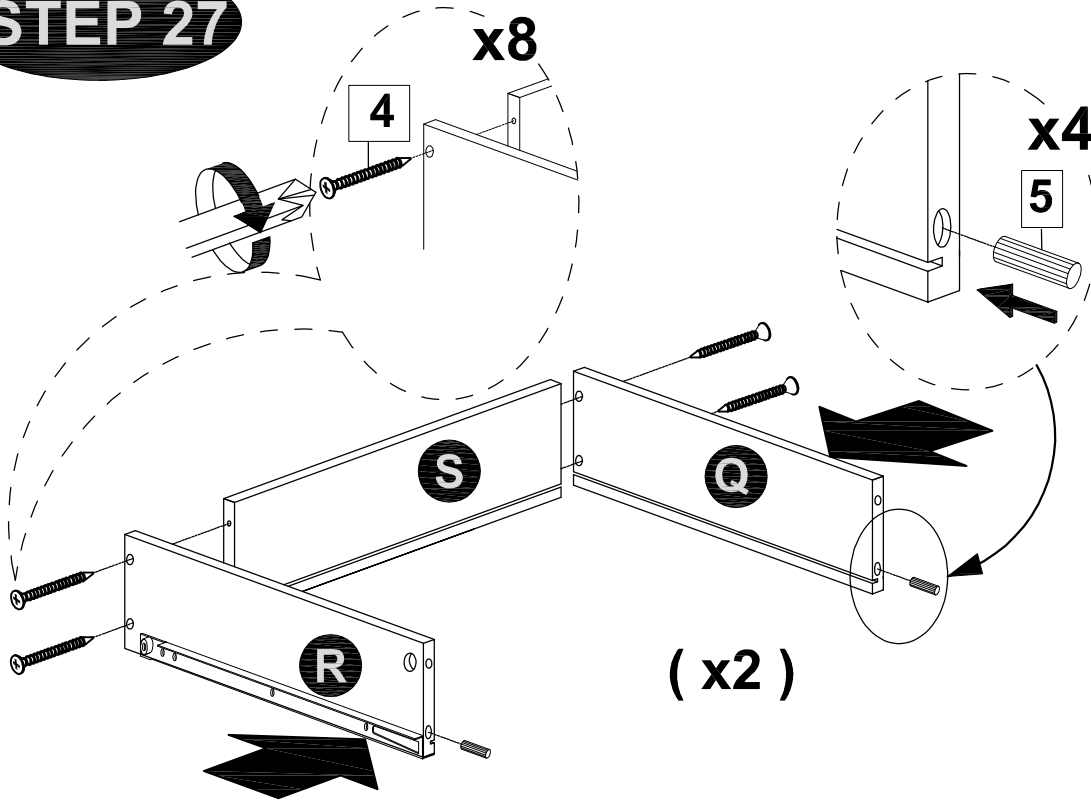

**STEP 28**

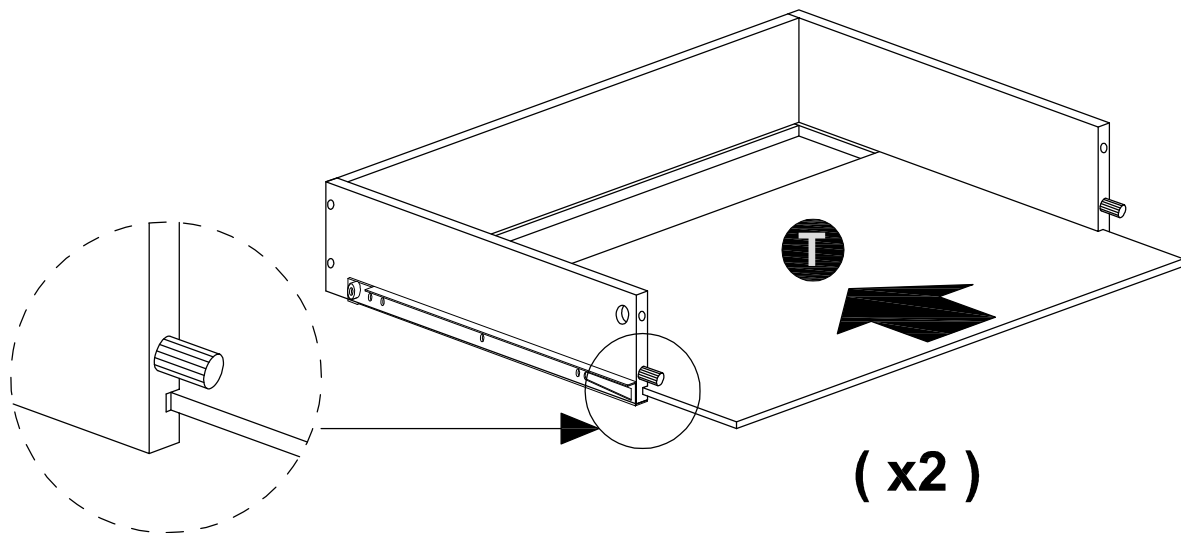

MODEL NAME:

ET 4915-00

**STEP 29**

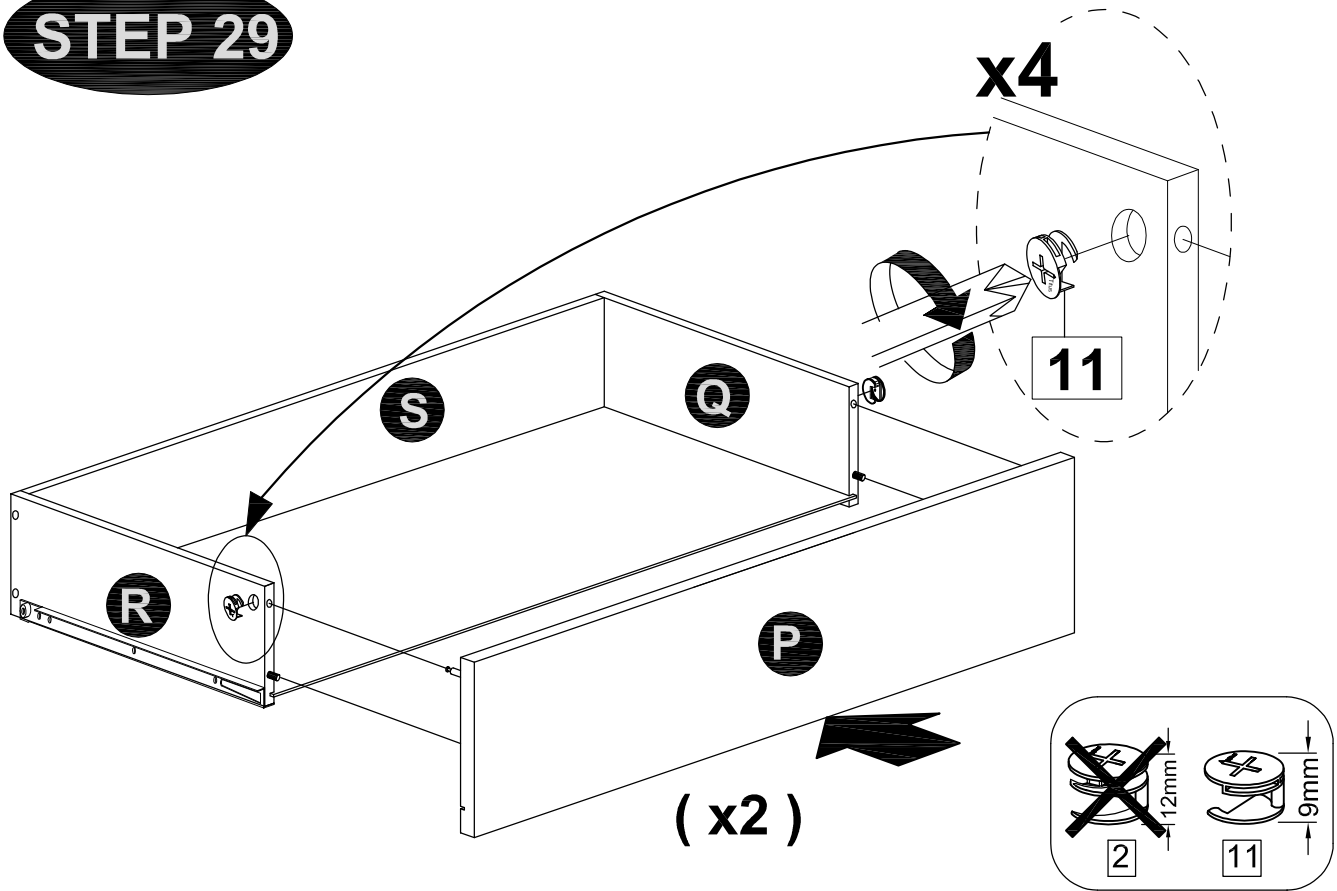

**STEP 30**

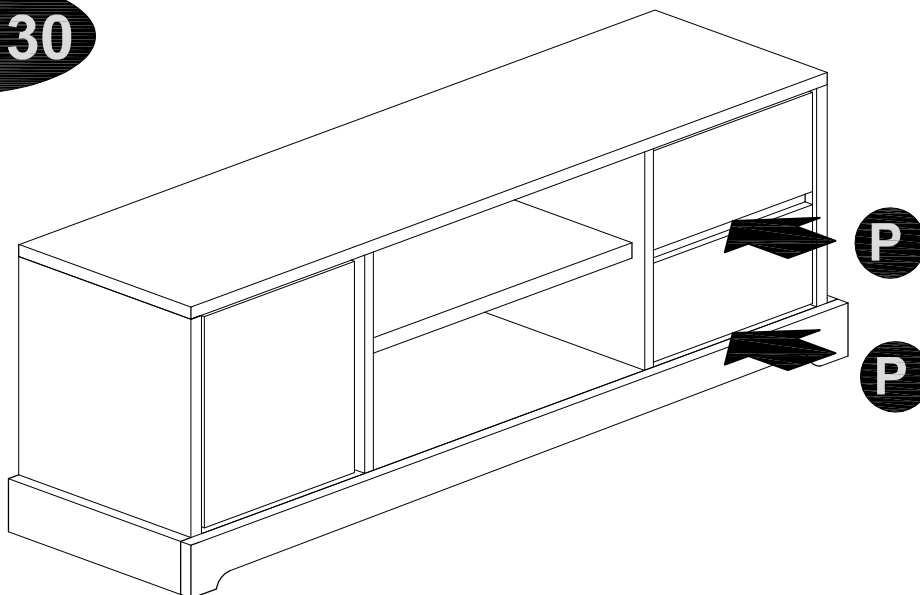

**MODEL NAME:**

**ET 4915-00**

**STEP 31**

