

## COMPONENT PARTS

## FITTINGS

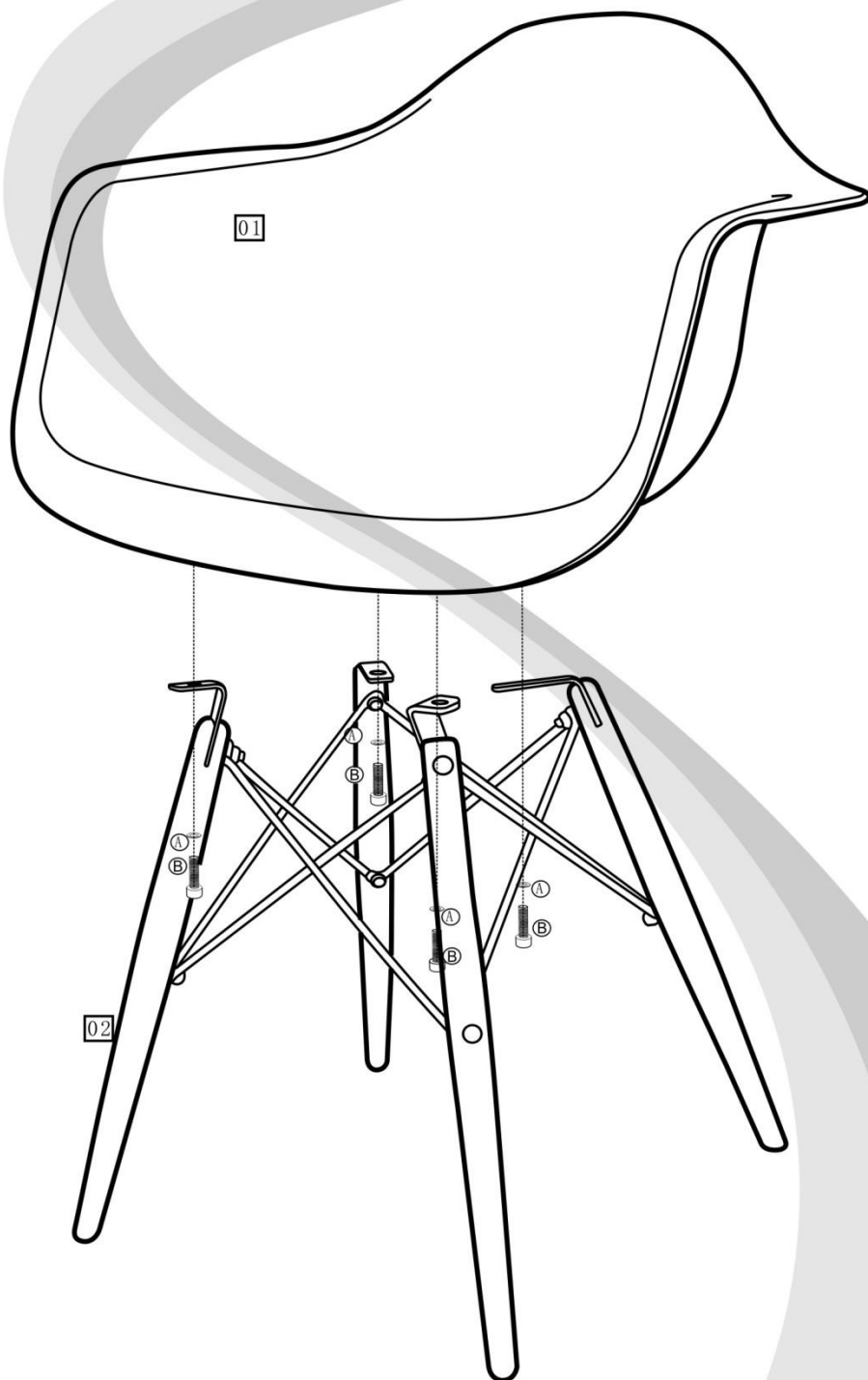

Ⓐ



\*4

Ⓑ

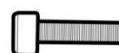

\*4

## COMPONENT CHECKLIST

PART	No.	Qty.	
Seat	01	1	<input type="checkbox"/>
Leg	02	1	<input type="checkbox"/>

## TOOLS REQUIRED



Allen key (supplied)