

















ASSEMBLY INSTRUCTION

ITEM : MD 308 LS/SF

NO	PART LIST	QTY
1	 BACK REST 1PC	1PC
2	 SIDE PANEL (L) 1PC	1PC
3	 SIDE PANEL (R) 1PC	1PC
4	 SIDE RAIL (FRONT) 1PC	1PC
5	 SIDE RAIL (BACK) 1PC	1PC
6	 LEGS 4PCS	4PCS
7	 SLATS 15PCS	15PCS
8	 SUPPORT RAIL 1PC	1PC
9	 POCKET SPRING 2PCS	2PCS
10	 SEAT CUSHION FABRIC COVER 2PCS	2PCS
11	 BLACK WOVEN COVER 2PCS	2PCS
12	 PLASTIC CAPS 30PCS	30PCS
ITEM	HARDWARE	QTY
A	 JCBB SCREW M8 x 20MM 8PCS	8PCS
B	 JCBB SCREW M6 x 50MM 4PCS	4PCS
C	 JCBB SCREW M6 x 80MM 2PCS	2PCS
D	 L - KEY M4 x 65MM 1PC	1PC
E	 L - KEY M5 x 65MM 1PC	1PC

STEP 1

Begin assembly by attaching the arms (2) & (3) to the front side rail (4) and back side rail (5). Then aligning holes and securing with 2 Bolts (A) per each by using L-key (E).

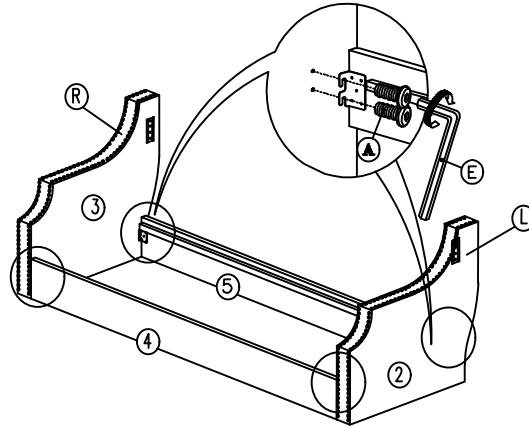

STEP 2

Attach support rail (8) to the each side of side rail cleat by using 1 Bolt (B) with L-key (D) per side.

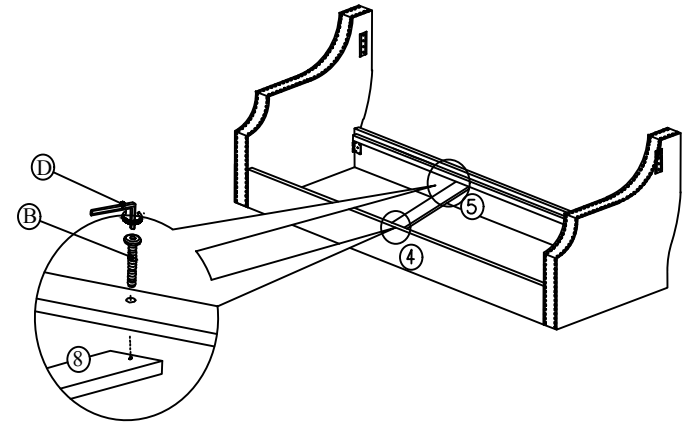

STEP 3

Installing the plastic cap (12) to each side of slats as shown in step 3.1 .
Then press each end of the slat to the front side rail (4) and back side rail (5) as shown in step 3.2.

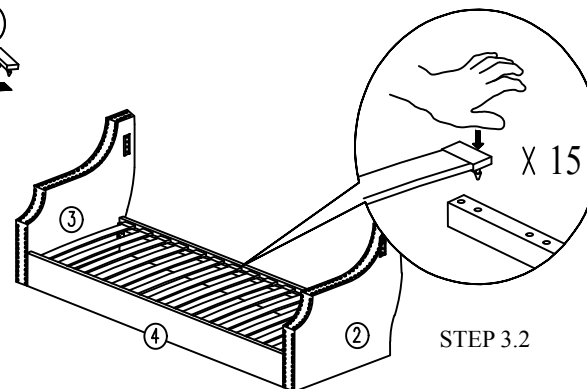
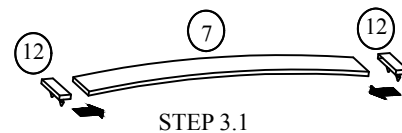

Please do not tighten then hardware until the entire assembly is completed.

ASSEMBLY INSTRUCTION

STEP 4

Insert the back rest metal plates to both arms (2) & (3) as shown below. Ensuring it is correctly in place.

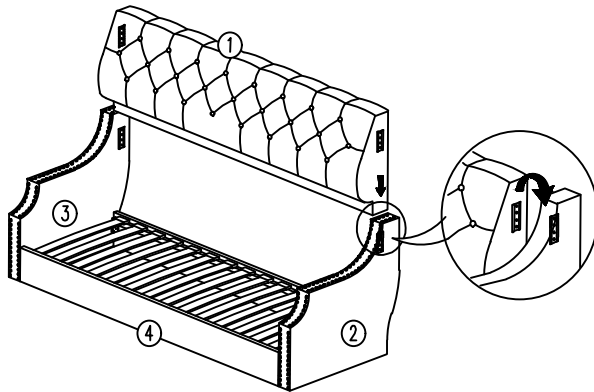

STEP 5

Securing with 1 Bolt (C) by using L-key (D) going through the pre-drilled holes on the cleat as shown in step 5.1.

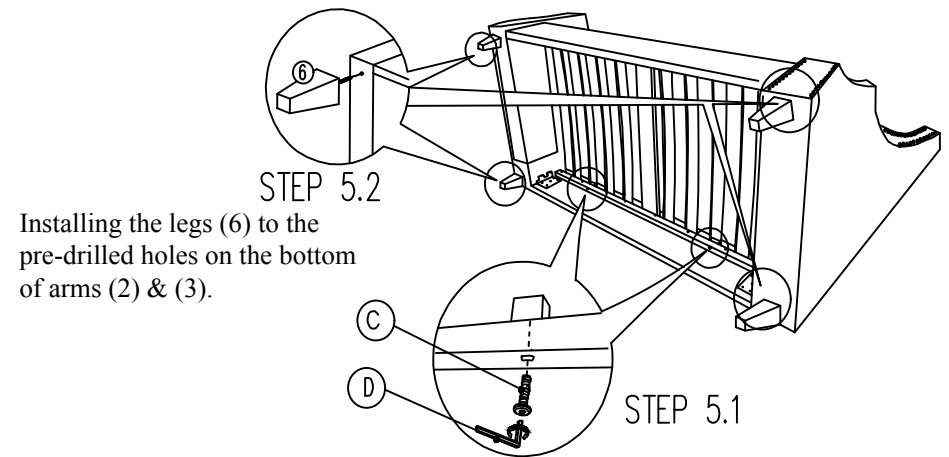

STEP 6

6.2 Inserting the unpacked pocket spring (9) to the black woven cover (11) then inserting into seat cushion fabric cover

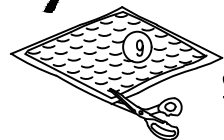
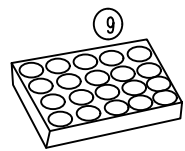

STEP 6.1

6.1 Unpack the pocket spring from vacuum bag.

STEP 6.2

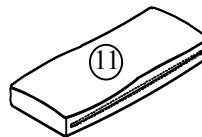
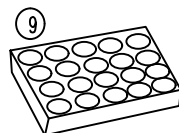
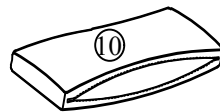
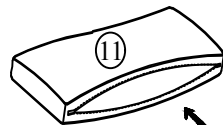

STEP 7

Put the seat cushion onto slats as shown below. Your assembly is now completed.

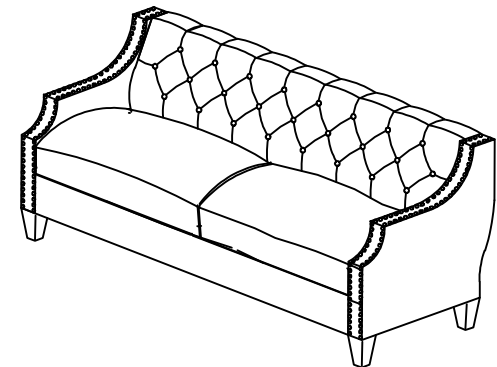

Please do not tighten the hardware until the entire assembly is completed.