









# ASSEMBLY INSTRUCTIONS

## MODEL : BLOOM BARSTOOL

- IMPORTANT NOTE :**
- \* PLACE ALL WOODEN PARTS ON A CLEAN AND SMOOTH SURFACE SUCH AS A RUG OR CARPET TO AVOID THE PARTS FROM BEING SCRATCHED.
  - \* BEFORE YOU BEGIN, KINDLY FOLLOW THE ASSEMBLY INSTRUCTIONS STEP BY STEP.
  - \* DO NOT TIGHTEN ALL SCREWS UNTIL THE CHAIR IS FULLY SET-UP.

HARDWARE LIST			PART LIST		
A	JCBC SCREW M6 x 45mm 	4PCS	1	LEG L/R	2PCS
B	SPRING WASHER M6 	4PCS	2	TOP STRETCHER	2PCS
C	FLAT WASHER M6 	4PCS	3	BOTTOM STRETCHER	2PCS
D	ALLEN KEY M4 	1PC	4	CUSHION SEAT	1PC
E	L-BRACKET 	4PCS			
F	WOOD DOWEL M8 X 25mm 	2PCS			
G	CSK SCREW M3.5 x 12mm 	8PCS			
H	FH SCREW #8 x 32mm 	4PCS			

### CAUTIONS :

(1) DO NOT FULLY-TIGHTEN THE NUT OR NUT BOLTS INITIALLY UNTIL ALL NUTS OR BOLT IS READY ASSEMBLED.

(TO AVOID CAUSING DAMAGES TO THE THREAD, DO NOT OVER-TIGHTEN THE NUTS OR BOLTS.)

(2) KEEP ALL HARDWARE PART OUT OF REACH OF CHILDREN.

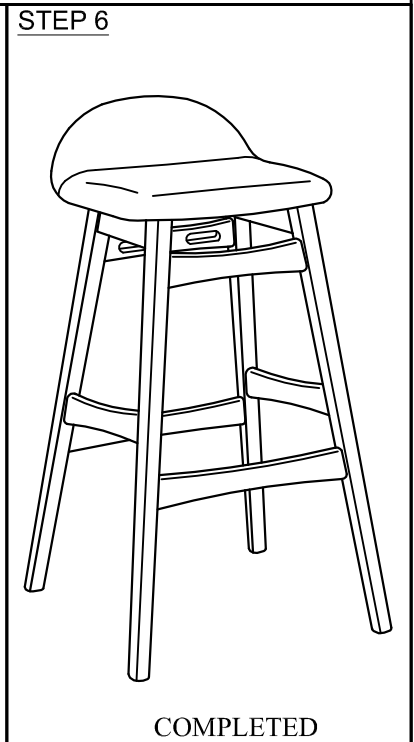
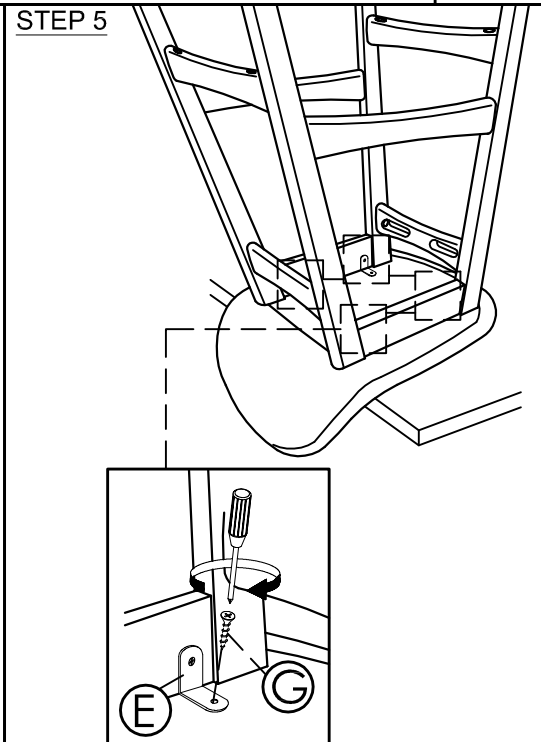
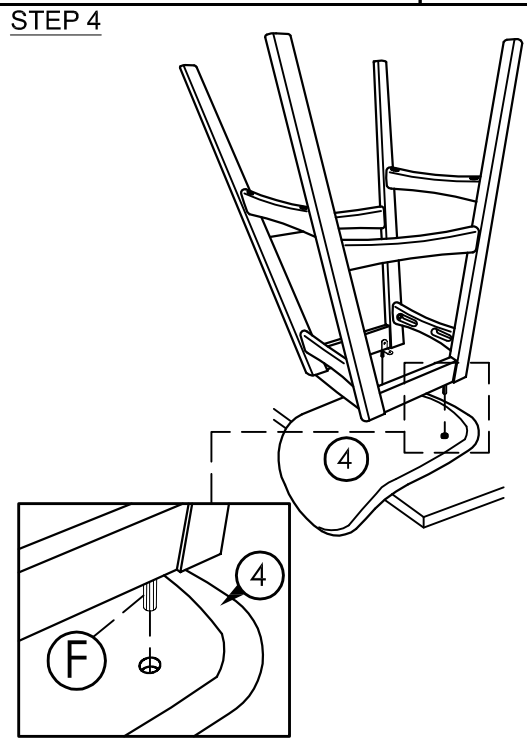
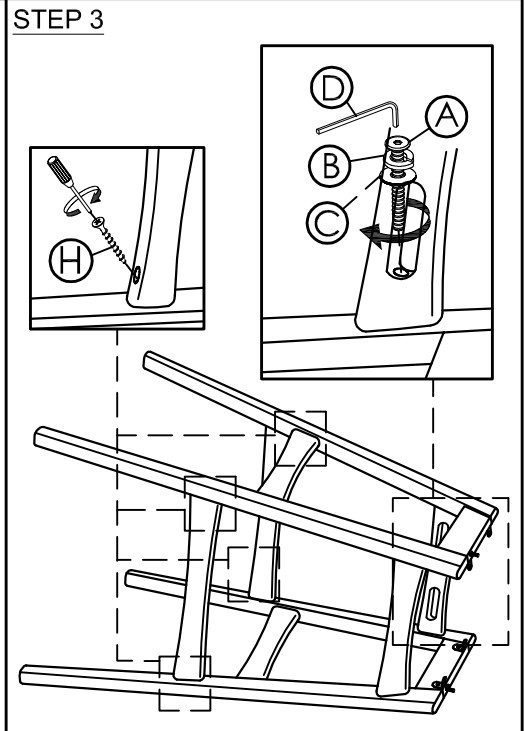
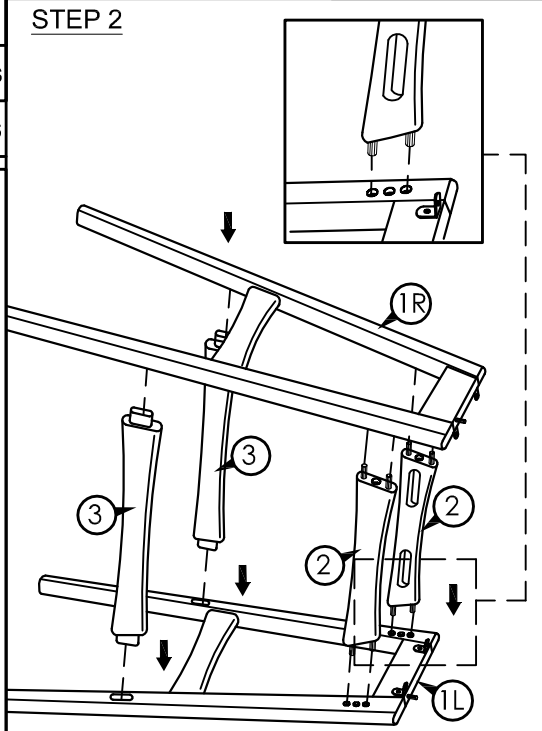
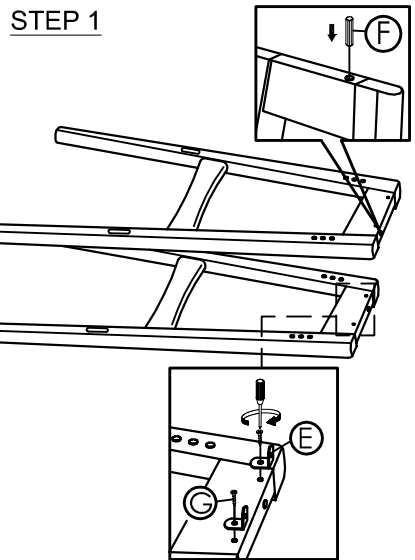

COMPLETED  
CHAIR ASSEMBLY.