

Read this instruction carefully. See hardware and furniture part list for guidance. Be sure all parts are complete, before you assemble. Place all wooden furniture parts on a clean and flat soft surface to prevent from being scratched. Follow the figure to start assembling.

- CAUTIONS :**
1. Do not FULLY - TIGHTEN the nut or nut bolt until all nut or bolt is ready assembled.
 2. Do not OVER - TIGHTEN the nut or bolt to avoid causing damages to the thread.
 3. Keep all hardware parts out of reach of children.

NOTE : THE LIST AND QUANTITY SHOWN ARE FOR 1 UNIT ASSEMBLY.

Tool needed : Screwdriver & Hammer (not provider).

PART LIST		
ITEM	DESCRIPTION	QTY
A	HEADBOARD	1 PC
B	HEADBOARD WING (L&R)	2 PCS
C	HEADBOARD SUPPORT	1 PC
D	FOOTBOARD	1 PC
E	SIDE RAIL (L&R)	2 PCS
F	CENTER RAIL	2 PCS
G	CENTER SUPPORT LEG	6 PCS
H	LEG	4 PCS
I	BED SLAT	1 SET
J	SIDE RAIL SUPPORT	2 PCS

HARDWARE LIST		
ITEM	DESCRIPTION	QTY
1	JCBC BOLT M6 x 45mm	18 PCS
2	JCBB BOLT M8 x 50mm	16 PCS
3	M6 SPRING WASHER	10 PCS
4	M6 FLAT WASHER	8 PCS
5	M8 SPRING WASHER	16 PCS
6	WOOD DOWEL M8 x 30mm	4 PCS
7	WOOD DOWEL M10 x 30mm	8 PCS
8	M4 ALLEN KEY (BALL SHAPE)	1 PC
9	M5 ALLEN KEY (BALL SHAPE)	1 PC
10	WOOD SCREW M4 x 38mm	12 PCS
11	M8 FLAT WASHER	16 PCS

STEP 1

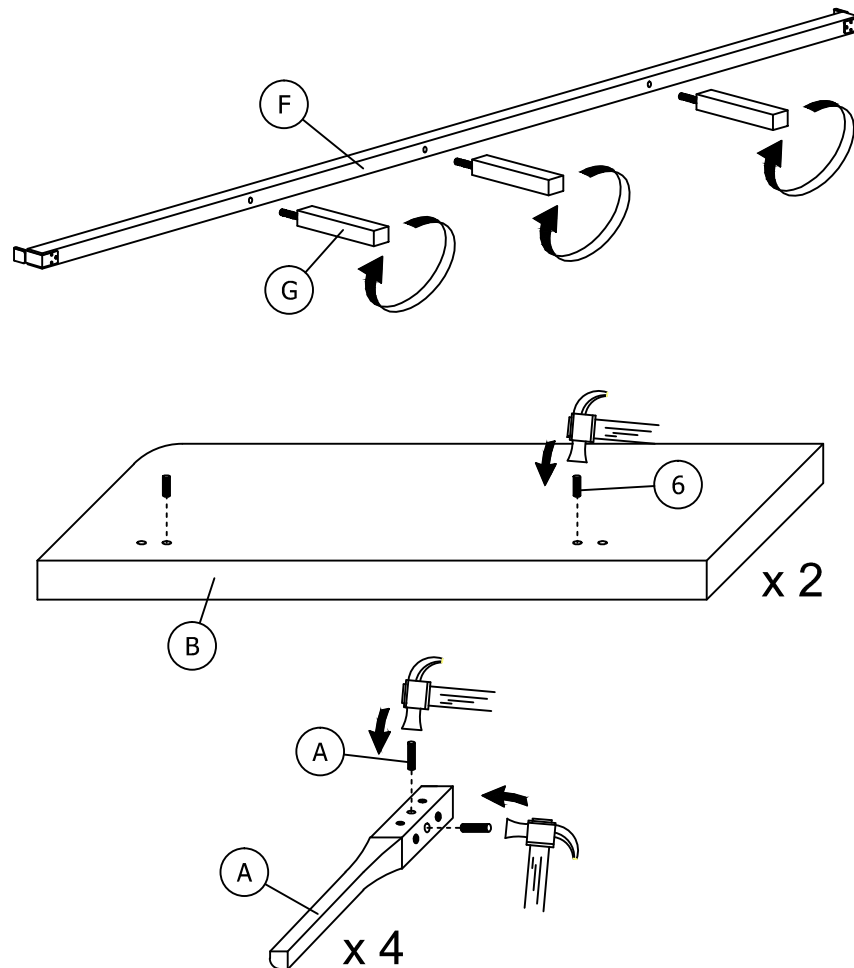

STEP 2

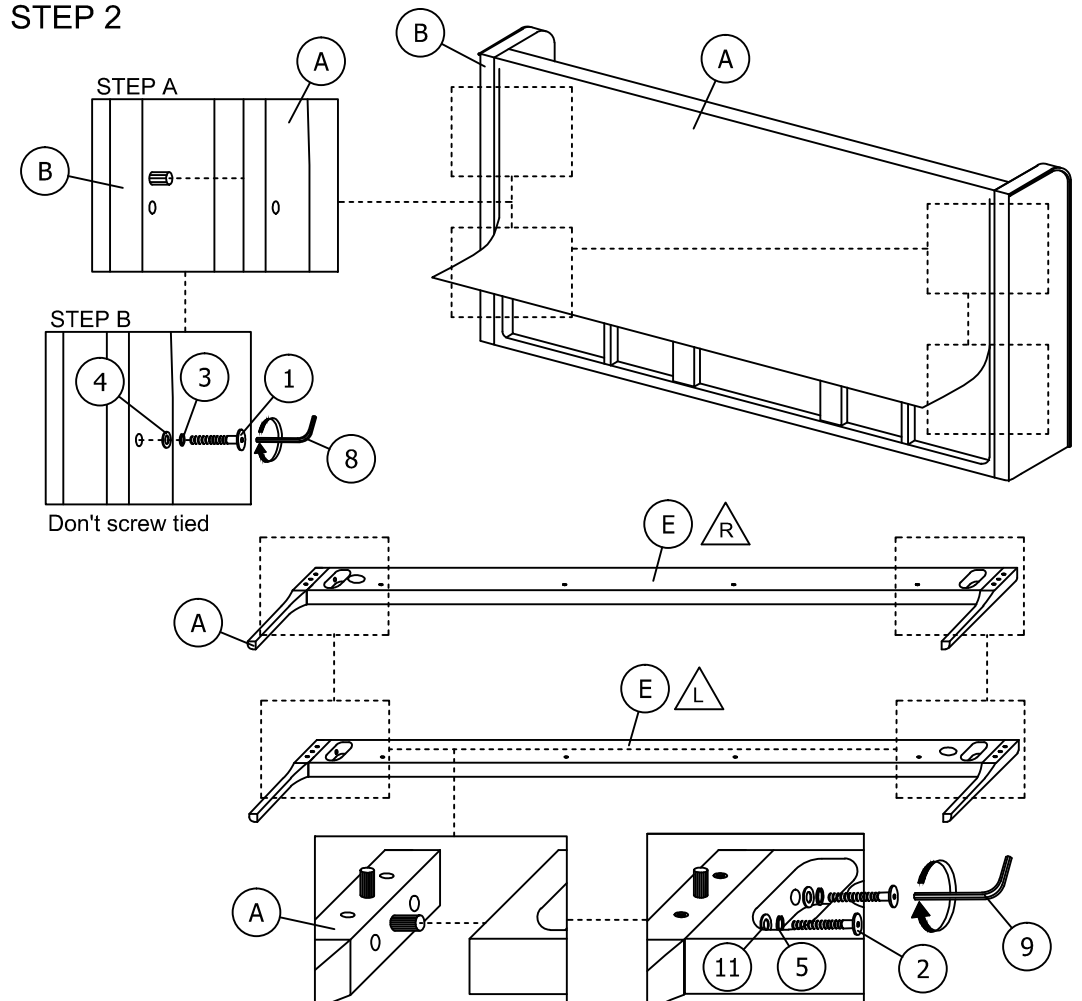

ASSEMBLY INSTRUCTIONS

STEP 3

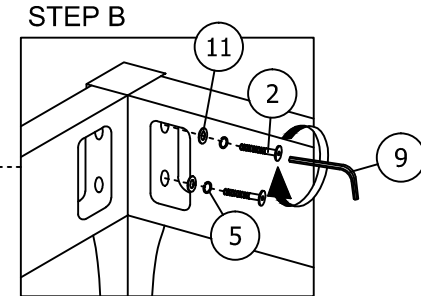
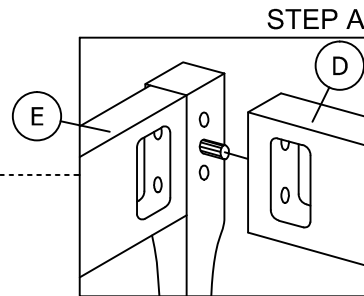
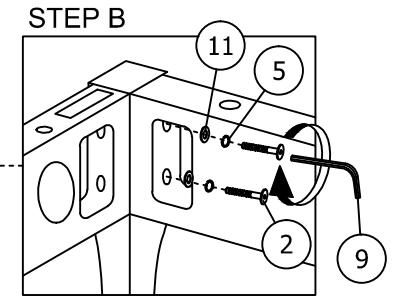
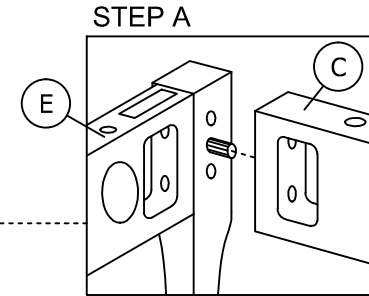
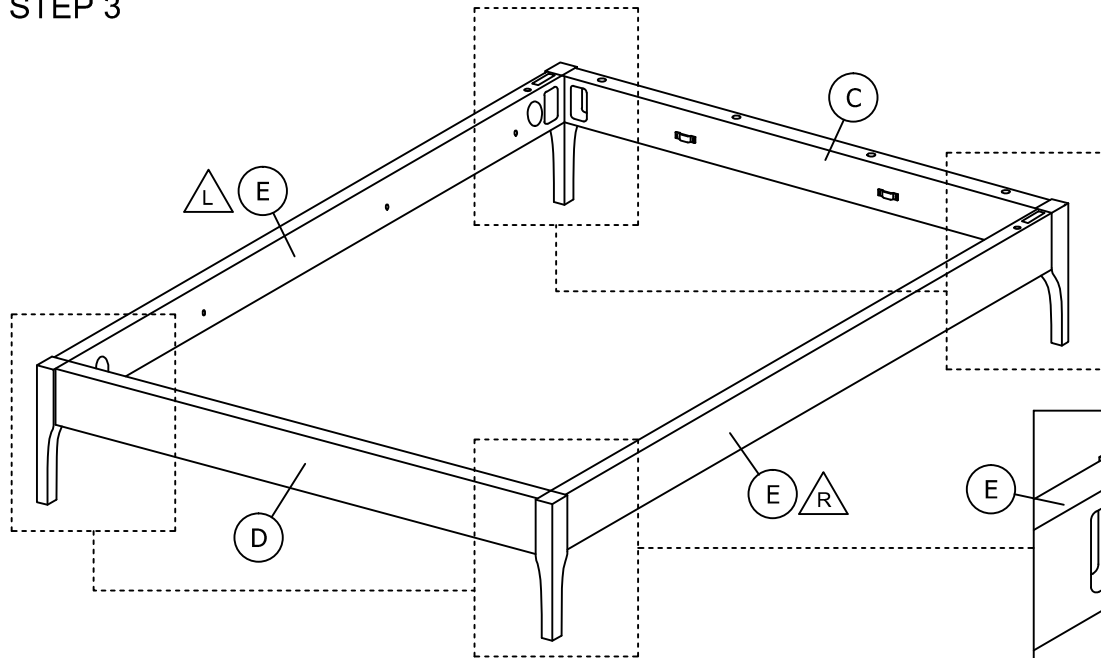

STEP 4

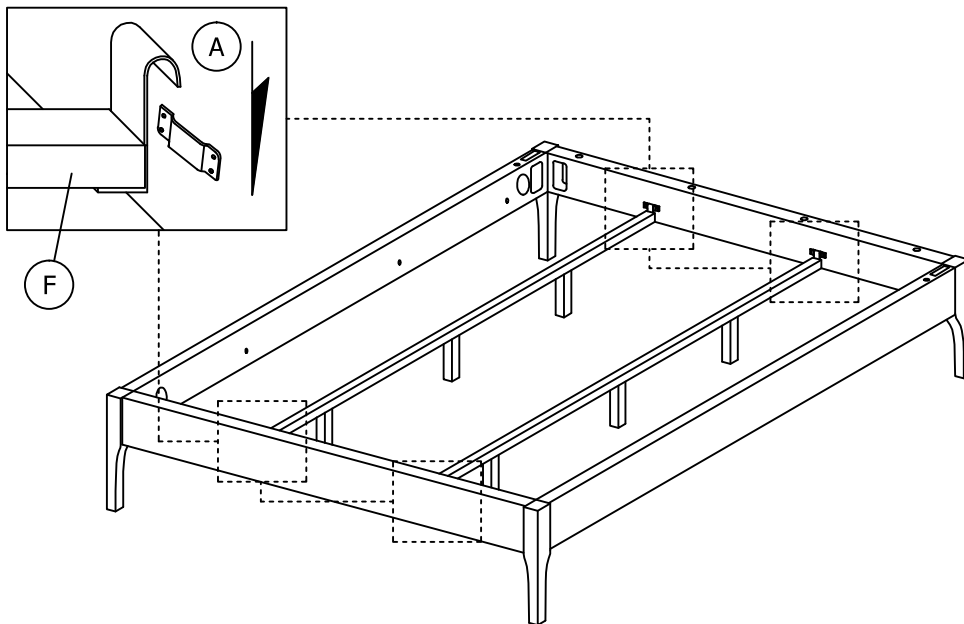

STEP 5

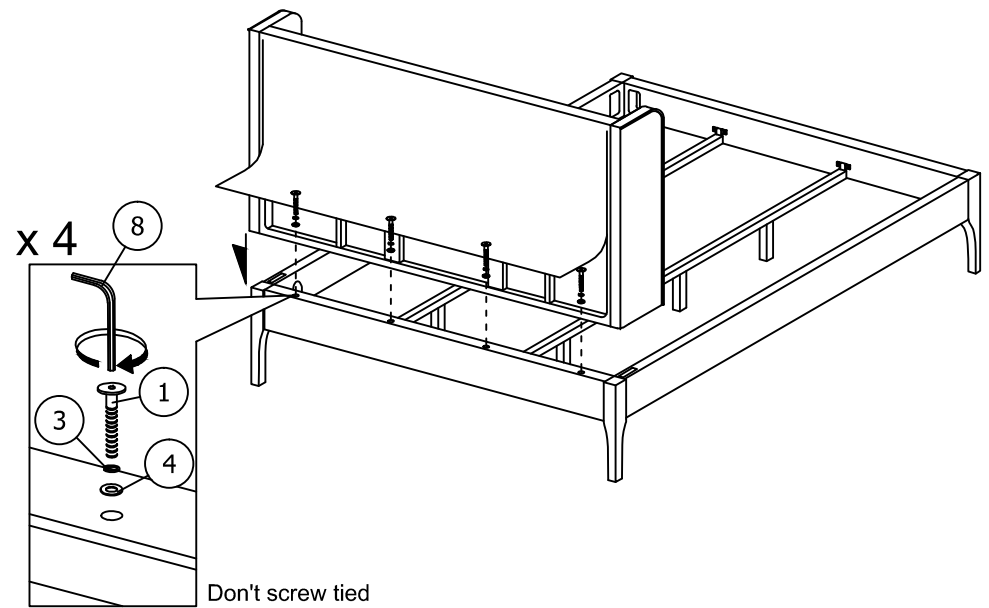

ASSEMBLY INSTRUCTIONS

STEP 6

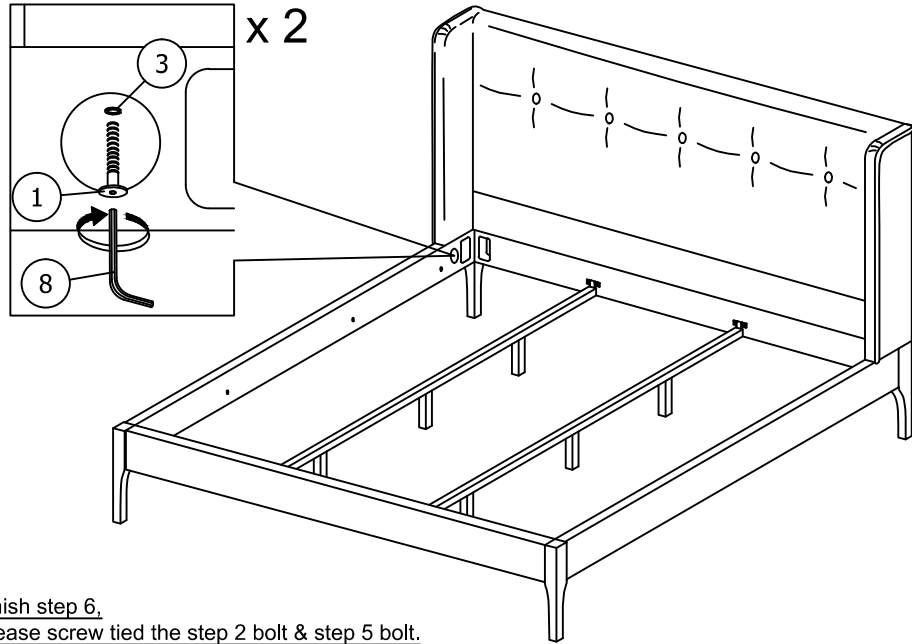

**Finish step 6,
Please screw tied the step 2 bolt & step 5 bolt.

STEP 7

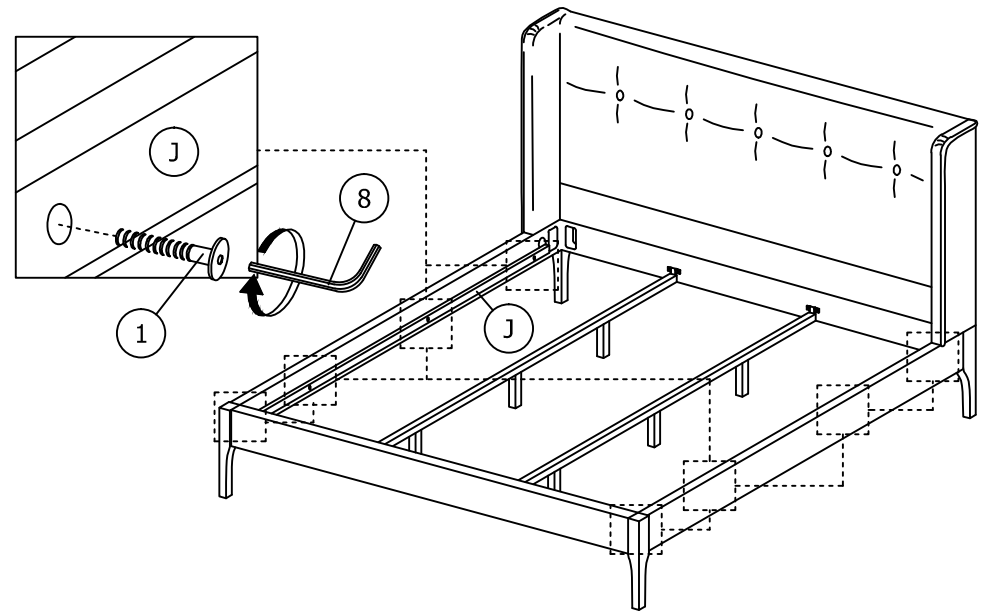

STEP 8

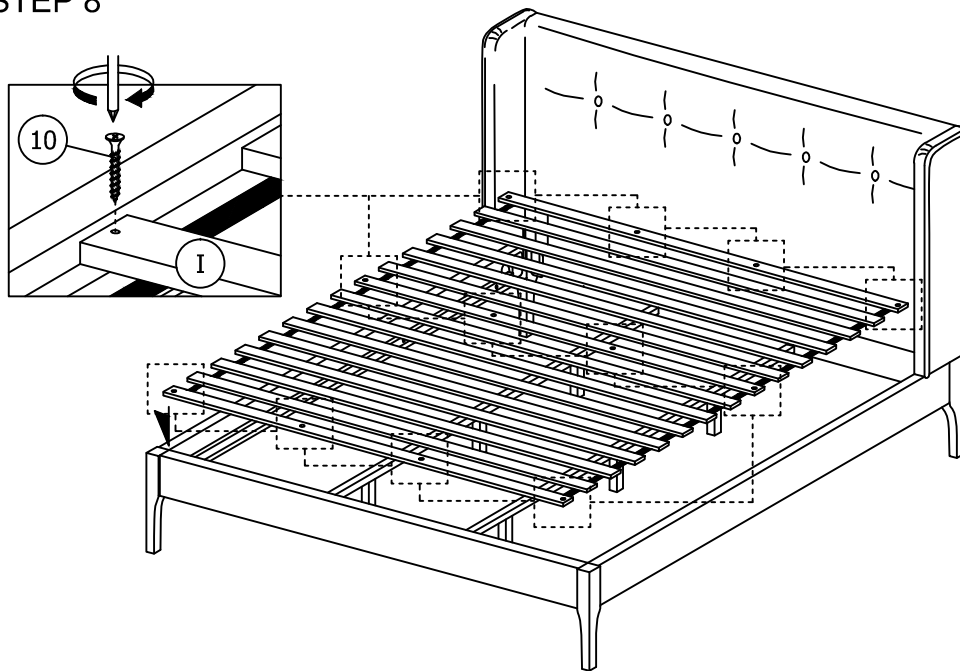

STEP 9

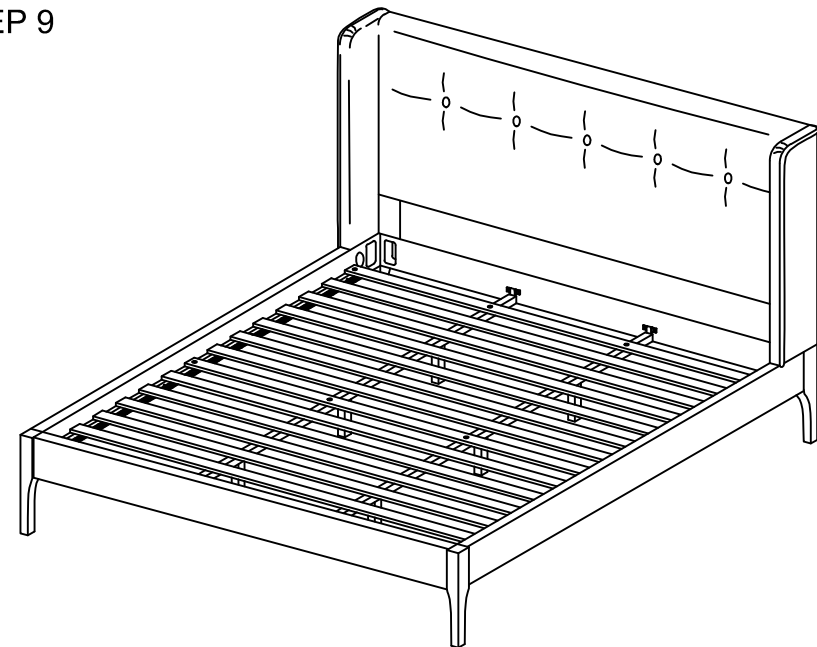

* When moving the bed position, the center support legs
must be adjust to be straight to avoid any broken problem.